



BIO RACER[®]
SUPERIOR CYCLING WEAR

WWW.BIORACER.COM

3	introduction
4	champions
6	innovation
12	shammy's
13	cycling fashion
23	tri fashion
28	skating fashion
32	indoor fashion
34	leisure wear
37	accessories
39	prodesigns
40	production process
42	bio-racer testcenter
43	materials and shammy's

foto: Cor Vos



We have a dream!

Whoever comes out with an innovative vision on society, art, technology or other issues of life often has to face the established order and inflexible ideas.

In the pioneer's roll which Bio-Racer has now fulfilled successfully for more than 20 years and wants to continue to fulfil, we have often had to face up to this. However, we never let this slow us down in achieving our ambitious objectives.

We have one well-defined mission: raising cycling comfort. By sending professional cyclists as well as the fine-weather cyclists on to the road with the best equipment and in the most progressive clothing.

We are in fact far more than just the prominent manufacturer of cycle clothing, who totally anticipates all your wishes. Bio-Racer is a real think tank, which searches for innovative solutions for everyday cycling problems. We therefore look further than our nose is long, collect information from cyclists and cycling professionals, enter into cooperation with renowned universities or research centres and invest countless hours and effort in testing all the innovations.

The results of all that thinking is first tested in the professional cycling peloton. When expanding, everyone who has ever mounted a cycle finally benefits from this.

The last thing that we are waiting for at Bio-Racer, is a statue. If we are satisfied that due to our innovations professionals can perform in improved circumstances, and that all cyclists feel comfortable, then that is reward enough.

This catalogue provides you with a glance behind the screens of the unique and pioneering Bio-Racer operation and at the same time allows you to make acquaintance with all our other strong points: almost unlimited flexibility, unparalleled quality, irrepressible creativity and an unparalleled level of service. Everything under one roof.

*Paul Herygers
Danny Nelissen
Bart Brentjens
Johan Museeuw
Mario De Clercq
De Wilde-Gilmore
Richard Groenendaal
Leontien Van Moorssel
Jurgen Van Den Broeck
Erwin Verweken
Bart Wellens
Filip Meirhaeghe
Bart Wellens
Sven Nys
Kenny Belaey
Tom Boonen
Dominique Cornu*

42 x gold - 29 x silver - 35 x bronze



Foto: Cor Vos





APPROVED BY CHAMPIONS

Perfectly suited to provide cycling comfort

Actually 'innovation' was already the core value of our company even before a company name was thought of. During the years in which Bio-Racer developed from a hobby project into trendsetting cycle clothing manufacturer, which occupies a prominent position in the cycling world, this concept naturally remained at the top of the list of priorities.

As an ex-cyclist and coach of top riders, Raymond Vanstraelen was dismayed to see day after day how most cyclists assumed a completely wrong cycling posture. This was far from comfortable.

A bicycle must fit you like a glove. The size of the frame, the adjustment of the handle bar and the saddle determine to a large extent the comfort on the bicycle and therefore also the performances.

Bicycle posture had always been determined by just a few rules of thumb and by feeling. Vanstraelen therefore invented a universal measuring system with the intention to approach as closely as possible the perfect cycling posture. Account was taken in the measuring system with the total body length, the width of the shoulders and the lengths of both feet, inside legs and arms.

This pioneering work is digitalized and integrated in a computer system; the birth of the Bike Fitting System! That makes it amongst other things possible to choose the correct frame size, to optimize the cycling position and get to the bottom of the physical complaints experienced by cyclists. A real hype started immediately around the Bio-Racer measuring system. If this system is applied by the top riders successfully, it will become of permanent significance in the professional peloton and the standard for the recreational cyclist.

The thinking process that preceded this innovation of twenty years ago is typical of the Bio-Racer operation. Even now we still first ask ourselves every day the question; "Which comfort problem for the cyclist can we still resolve, and how?"



PHASE 4



BETTER CLOTHING

PHASE 3



RESKIN PATCH

ReSkin
PROTECT AGAINST FRICTION

PHASE 2

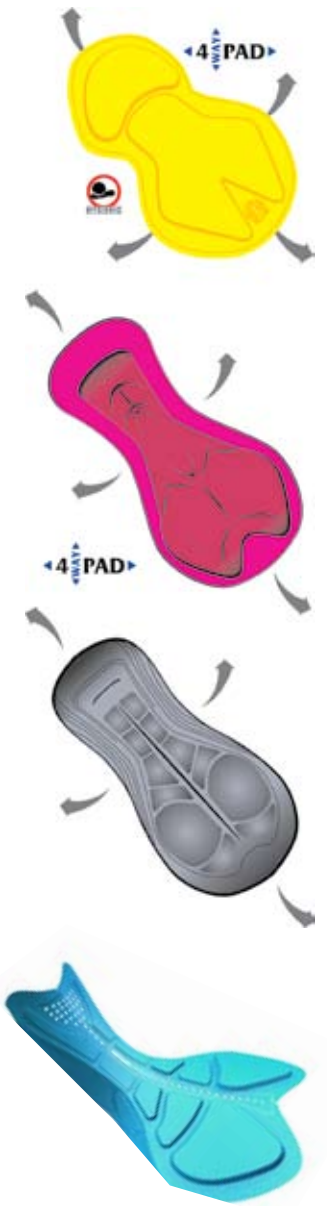

BETTER CYCLING PADS

PHASE 1



BETTER BIKE POSITION

SADDLE PRESSURE MEASUREMENT

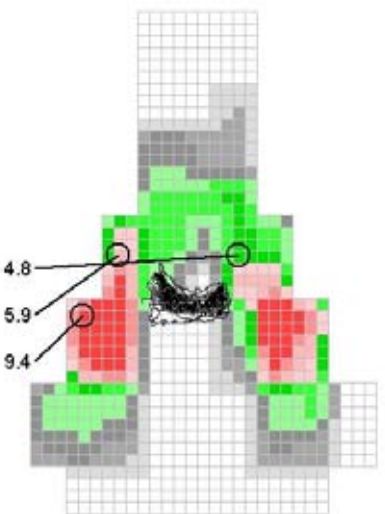

BIKE FITTING SYSTEM

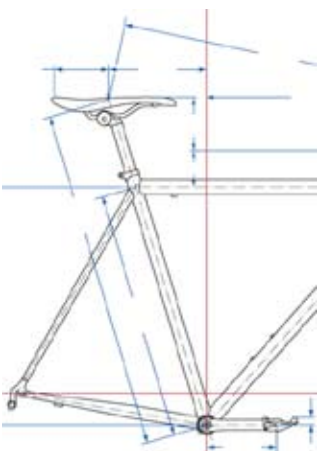

Innovation is a means, not an objective

At the top of our banner, written in capitals, is 'INNOVATION'. Innovation for innovations sake, is however altogether wrong. Our drive for innovation is certainly the principal pillar on which the Bio-Racer operation rests; a permanent pursuit of greater cycling comfort. We don't sell hot air. Even less do we copy what others produce. During the past twenty years you could already benefit from this continuous thinking and testing process. And the bottom of the barrel of creativity is still nowhere in sight.

Pioneering work from Bio-Racer's past

Airstripe

During the 1980's a remarkable development took place in cycling clothes. Lycra, a fabric that had been all the rage in the skiing world, made its entrance in the cycling peloton. Excellent news for all those cyclists who for many years cursed the poor comfort of the cycling shorts in use at that time. Especially the manner in which the chamois was integrated into the shorts, caused inconvenience and irritation. Out of concern for the sitting area of the cyclist Bio-Racer developed a pair of shorts with the very first seamless chamois: the Airstripe. This chamois unleashed a revolution in the cycling world and now, in all its improved versions, it is impossible to imagine cycling clothes without it.

Caro

A fabric that feels like a second skin and that optimally supports the muscles. These requirements formed the basis of the development of a new high-technology type of acryl. The result - Caro - is a fabric which fits closer than other lycras. Muscle vibrations are reduced to a minimum. The athlete tires less quickly and the performance loss is minimal. The unique roughened structure ensures that efficient use is made of aerodynamics and due to its special texture the textile offers excellent protection against friction. In combination with a perfectly thought out fit this fabric guarantees extra support where it is needed and increases comfort. It is an exceptional trump card, which Bio-Racer can play for many years when manufacturing high quality racing shorts.

Cool Light 100

At a time when an average cycling jersey weighed approximately 300 grams, it seemed impossible to reduce the weight of a shirt by two-thirds. However, that didn't take account of Bio-Racer. During preparations for the Olympic Games in Athens we developed a new, super-lightweight jersey, which was worn by both the Belgian and Dutch national teams. The gain in weight - the Cool Light 100 weighed only 100 grams - was achieved by treating the textile used, Coolmax™, in a revolutionary manner with the help of nanotechnology. Micro-perforations in the front and sides resulted in extremely high air circulation. The cut was radically changed, resulting in pleasant ventilation, without the shirt catching the wind. Wearing this shirt, various national teams collected a catalogue of medals and world titles.



Cool Light 100

Airstripe

Caro

The technology of tomorrow, applied today

Bio-Racer Mach 1

When Dominique Cornu was crowned world champion time trial in 2006, he was not only driven to the winning time by a pair of strong legs and a considerable dose of talent. He found an extra ally in his time trial costume, the Bio-Racer Mach 1 skin suit, an innovation from our company's R&D team. Improved aerodynamics was an important, but not the only trump card of this costume. The muscles are better supported and the level of comfort has been raised. The number of creases in the textile has been reduced to a minimum in the design and because the costume is almost seamless, it fits so closely that it appears as if the cyclist is wearing body paint.

Airstream

Although chamois is one of the most important elements in cycling clothes, there was little research done into it in the past. During the search for an innovative comfort chamois Bio-Racer placed the bar very high for itself: all benefits and qualities presented had to be substantiated scientifically. With the help of pressure point measurements the where and why of saddle-soreness was defined. The information from these sitting-area scans formed the basis for the subsequent development of the Airstream: a chamois that with regards to the comfort level leaves the competition far behind. The Airstream will be available in the shops in September 2007.

The long path to future success

Already two years before the 2008 Olympic Games Bio-Racer has started with the preparations for this major sporting event. In Peking, the Dutch racing cyclists will perform in a new type of aerodynamic costume, the Mach 2. Because this costume is completely cut to size for the Olympic track racers, prominent track cyclists were involved from the start by the development and testing of this innovation. Furthermore, this innovation is based on findings and experiences which we gained with our skating clothing. For example, the revolutionary Aerocoat - a special supporting aerodynamic coating that we use with success on our Power skating costumes - will also be incorporated into this high-tech cycling costume.





Not sitting still for a minute, always thinking ahead

A striking example of the Bio-Racer approach to the development of new products is the search for a comfort chamois. The basic assumption thereby was that the benefits and qualities presented must be substantiated scientifically. A unique event in this market segment.

Several product designers gradually threw themselves at this challenge.

“How can we define the quality of a chamois?” The key issue of this project. The developers set off by gaining more in depth knowledge of some medical aspects, such as skin functioning and saddle-soreness. A system is needed to measure pressure and friction on the saddle. That was found at the biomedical GEBIOM University of Munster (Germany): a futuristic looking saddle cover with 40 pressure points. A self-developed software programme will analyse the future data, so that the choice of fabric can be based on objective numbers and not on a subjective feeling.

As a reference point one of the researchers mounts time after time without chamois a carbon saddle. It is measured each time where the maximum pressure is found and why. In a subsequent phase the same testee repeats these measurements, each time using a different chamois available in the market and which was approved of by the users.

The same tests are then repeated by other testees, including young cyclists and the national track team. It is, after all, the intention to design the best chamois, for as large a public as possible. An analysis of the matrices makes it clear which main approach must be followed. On that basis the fiddling begins; type of foam rubber, thicknesses, densities and combinations of fabrics are subjected to innumerable test rides. Tests on dozens of prototypes follow. Only after the final choice of the fabric is it time for the design. The cooling receives extra attention with the help of a tunnel effect. Our comfort chamois “AIRSTREAM” will be available in the shops in September 2007. Thanks to the earlier research we can prove scientifically that this is the best product on the market.

ReSkin Bike Patch

In countless contacts with both professionals as well as weekend cyclists, Bio-Racer was repeatedly confronted with sitting area problems. During the research into the comfort chamois the product designers came to the conclusion that saddle-soreness in many cases is a result of friction. As a spin-off it was therefore decided to start with the development of a solution which must prevent this friction. The requirements which were placed on this solution were not simple: optimal prevention against friction, improved sitting comfort, good removal of heat, transport of perspiration, hygiene and ease of maintenance. Too many elements to work out completely on our own. Therefore cooperation was again entered into with specialists, namely the textile engineers of the Gent High School. It was clear fairly quickly that the solution must be sought in a system that attaches to the skin, provided with a therapeutic gel coating. Only after numerous professional cyclists reacted enthusiastically to the product, the result of this cooperation was brought to the market: ReSkin, an innovative sitting area plaster which breathes, is skin-friendly, easy to use and even washable. Since then tens of thousands of buttocks are grateful to Bio-Race for this invention. Anyone who knows us a little knows that the story doesn't end here. The invention of the revolutionary bi-elastic plaster was too good and too valuable to only reserve them for the cycling population. In the meantime we developed along with the Bike Patch a model plaster that protects the body against friction at several places. The Feet Patch offers specific protection to runners and walkers and an adjusted model was also created for motor crossers.



Pampering the sitting area

Because saddle-soreness can seriously spoil the pleasure of cycling, the contemporary cyclist is in search of a chamois that gives every comfort to the sitting area. As a trendsetter Bio-Racer is constantly looking for new fabrics for its chamois leathers, which allow you to remain even longer in the saddle.

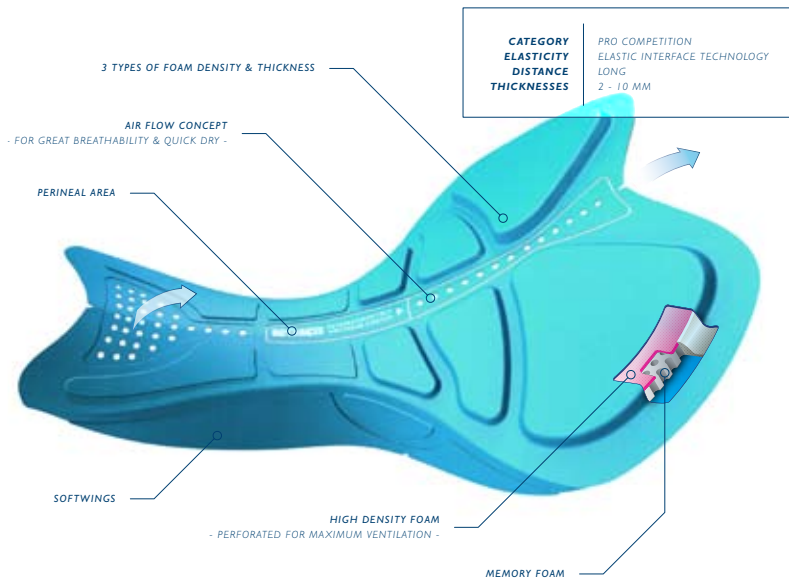

MLP

Multi-Thick is our high-end standard chamois that is elastic in four directions. The differences in height in the chamois guarantee extra protection at the saddle pressure points. Our professional test candidates would not want to exchange this chamois for any other.

3D

The absolute pinnacle when it comes to comfort! This chamois is bodily elastic. In other words: it perfectly follows the curves of the body. The top layer is manufactured from a microfibre which reduces friction. Strategically positioned padding with different densities ensures a better support for some areas of the seat, such as the seat bones. On other places the chamois reduces the pressure. The perforated under layer guarantees the fast removal of perspiration.

Bio-racer Airstream

The crème de la crème for the demanding cyclist. Thanks to the analysis of data, obtained from hundreds of seat scans, Bio-Racer succeeded in developing a chamois, which comfort's level was miles ahead of the competition. The use of new fabrics in various thicknesses, an Air Channel which ensures extra ventilation from the sitting area. These are only a few of the scientifically substantiated innovations by which the Airstream helps the cyclist to sit comfortably in the saddle in the most extreme circumstances. This chamois is sold in two versions, for cyclists below and above 75 kg.

Airstream Ladies

Bio-Racer has also thought about the demanding female cyclist. The test data that we obtained from numerous sitting-area scans with female cyclists were incorporated into this new chamois. It has the same comfort raising properties as the Airstream for men and is provided with an Air Channel for improved ventilation and removal of perspiration.

Triathlon Shammy

This chamois has been specifically designed for tri-athletes. It ensures optimal comfort during cycling in combination with maximum freedom of movement.

Feedback from winners

Through the years Bio-Racer has entered into strategic alliances with cycling teams at various levels: from national teams and Pro-Tour teams to excellently organised amateur teams. Because they provide so much useful information, all our customers eventually benefit from these collaborations.

Whenever you call on us for customized team clothing, then you have a right to only the very best. To ensure that the clothing always satisfies your requirements, we subject them to a test at the very highest level or from the most demanding cyclists.

That's why more than ten years ago we entered into partnerships with the national Belgian and Dutch cycling associations, for all the teams who defend their country's honour; on the road, in the field, on the track and with the mountain bike.

As an innovative clothing sponsor we worked and work together with dozens of professional and semi-professional teams and individual top riders, spread across road cycling, cyclo-cross, mountain biking and the triathlon.

The experience of the cyclists in these teams with the Bio-Racer equipment, and especially the feedback which we get from them, allow us to continually improve the quality of the products. Production processes are accelerated, the quality of the fabrics and finishing is improved further and the price evolves even more favourably. In short: these partnerships are also to your benefit.



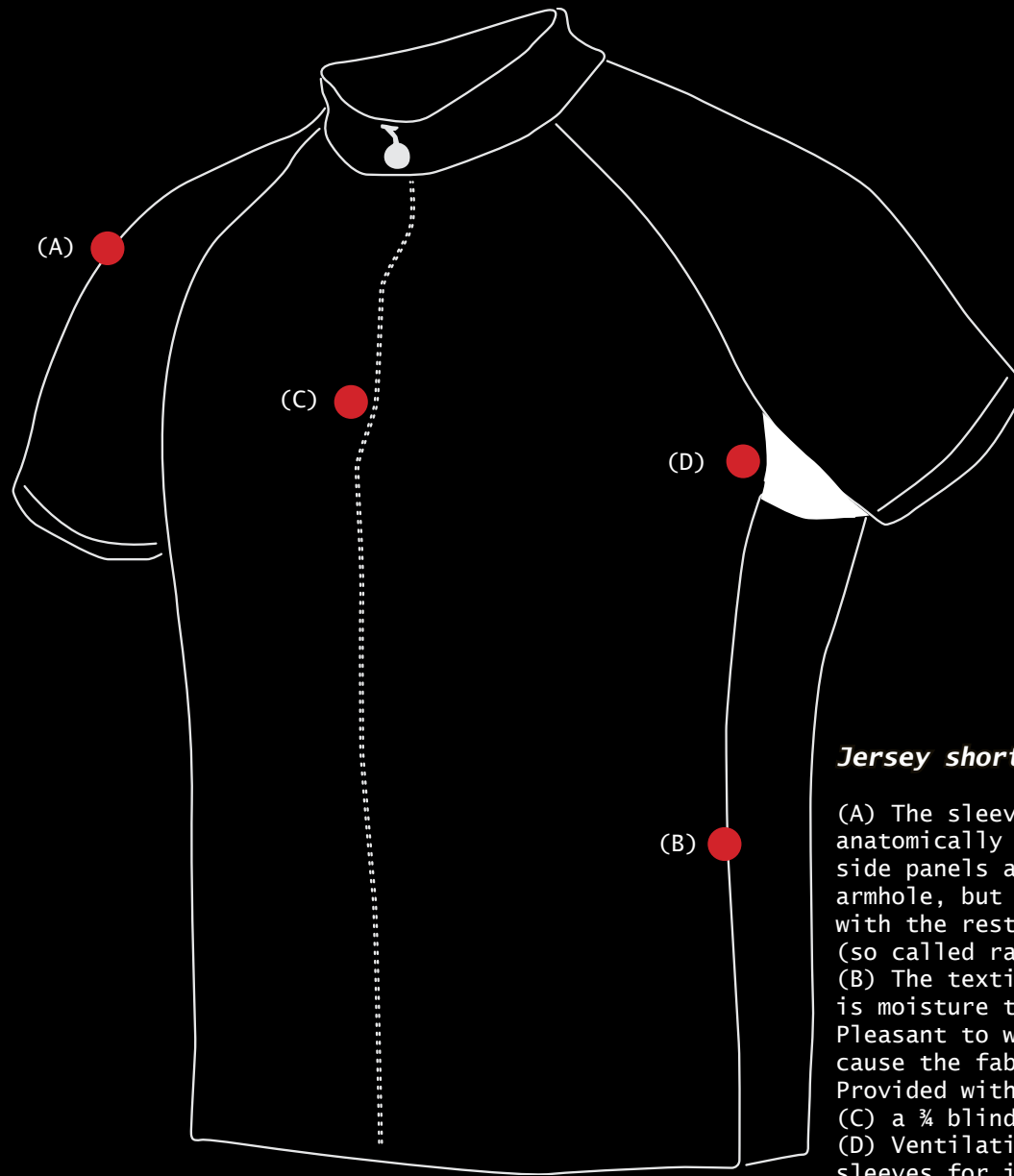

Jersey short sleeves

(A) The sleeves of this anatomically shaped shirt with side panels are not fitted in an armhole, but they form a whole with the rest of the garment (so called raglan sleeves).
(B) The textile dries quickly and is moisture transporting. Pleasant to wear, certainly because the fabric resists tearing. Provided with 3 back pockets and (C) a $\frac{3}{4}$ blind zip.
(D) Ventilating inserts under the sleeves for improved aerodynamics and comfort. Option: flatlock seams
Available fabrics: Airtex (51328) and Quadri (51338).



**Jersey Athens Cool Lite 100g
(51326)**

Lighter is almost impossible. This anatomically shaped shirt with raglan sleeves and side panels only weighs 100 g. That is 70 % less than a normal cycling jersey. The Cool Lite textile fibre breathes and removes fluid. 3 back pockets. ¾ blind zip. Ventilating inserts under the sleeves for improved aerodynamics and comfort. Option: flatlock seams

Available fabrics:





Jersey Sleeveless (51228)



- Anatomically shaped, sleeveless shirt with side panels
- Quick drying and fluid carrying fabric
- 3 back pockets and a short zip



Jersey long sleeves Isolation (51428)



- Anatomically shaped cut, with raglan sleeves and side panels
- 3 back pockets and a long zip
- Light and highly insulating fabric. Pleasant touch. Quick drying and moisture transporting.



Jersey long sleeves Transotex (51430)



- Anatomically shaped cut, with raglan sleeves, side panels and 3 back pockets
- Thermastat fibres were incorporated on the inside
- The Transotex fabric has a pleasant feel to it, dries quickly, removes perspiration and has tear-proof properties.



Vest Windblock/Gamex Netz

- Anatomically shaped body with extra side panels
- Rear in Netz for better ventilation
- A flap behind the zip for extra insulation

Available fabrics:



Vest Windblock

- Anatomically shaped body with extra side panels
- Manufactured from highly insulating, stretchable and breathing Windblock fabric
- 90% waterproof, windproof and easy to fold up
- A flap behind the zip for extra insulation
- Available in Windblock (51923) or the slightly warmer Winter Windblock(51921)





Jacket Windblock/Gamex

- Anatomically shaped wind-breaker, with raglan sleeves and side panels
- It can be folded up easily and small
- Ventilating inserts under the sleeves for improved aerodynamics and comfort

Available fabrics:



(56422)



(51515)



Jacket Windblock Winter



- Anatomically shaped vest with extra side panels and raglan sleeves
- Ventilating inserts under the sleeve
- A flap behind the zip for extra insulation
- Manufactured from Windblock of a slightly heavier and warmer quality with a padded lining.
- Available with 3 back pockets (51512) or a zipper pocket (51513)

Bibshort Professional

This exceptional six-panel pair of shorts combines an excellent finished quality with maximum freedom of movement. The braces are manufactured in elastic Eyelet. The finishing with flatlock seams guarantees extra firmness and comfort. As an option we can incorporate the chamois of your choice. The bottoms of the short's legs are finished with a special Tektape® Anti-slip strip.

Standard chamois: 3D

Option: choice of chamois / flatlock seams

Available fabrics:



(S2127)



(S2128)



(S2138)



Short Professional

- Six panels • Exceptional finished quality and maximum freedom of movement • The bottoms of the short's legs are finished with Tektape® Anti-slip strip • Flatlock seams for extra firmness and comfort
- Standard chamois: 3D • Option: choice of chamois / flatlock seams

Available fabrics:



(S1827)



(S1828)







Tight Professional

- Six-panel shorts with sidepieces and braces
- Maximum freedom of movement
- Standard delivered without chamois
- Option: choice of chamois

Available fabrics:

 Bibtight(53529)
Regular tight(53429)

 Bibtight(53528)
Regular tight(53428)

 Bibtight(53518)



Knicker Professional

- Six-panel three-quarter length shorts with sidepieces
- Maximum freedom of movement
- Standard chamois: MLP
- Option: choice of chamois

Available fabrics:

 Knicker Bib(54418)
Regular Knicker(54318)

 Knicker Bib(54428)
Regular Knicker(54328)





Short sport

- Six panels with side pieces
- Maximum freedom of movement
- Available with or without braces
- Standard chamois: MLP
- Option: choice of chamois

Available fabrics:

 Bibshort(52206)
Regular Short(52306)

 Bibshort(52207)
Regular Short(52307)

 Bibshort(52216)



Tight Sport

- Six-panel tight with sidepieces
- Maximum freedom of movement
- Standard delivered without chamois
- Option: choice of chamois

Available fabrics:



Bibtight Sport

- Six-panel Lycra shorts with sidepieces and braces
- Maximum freedom of movement
- Standard delivered without chamois
- Option: choice of chamois

Available fabrics:



Knicker Sport

- Six-panel three-quarter length shorts with sidepieces
- Maximum freedom of movement
- Standard chamois: MLP
- Option: choice of chamois

Available fabrics:

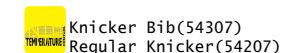
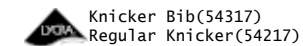



Aerosuit Professional

- Aërodynamique fit with maximum freedom of movement
- Highly elastic
- Transports perspiration
- The bottoms of the short's legs are finished with Tektape® Anti-slip strip
- Available fabrics: lycra (56534) and caro (56538)





Tri-suit Lycra Women (56418D)

The largest differences with the Tri-suit for men are zips placed at the rear, the shorter legs of the shorts and the side panels which can be used for printing sponsor information. For the rest: a perfect fit, maximum freedom of movement and an ultra-light, quick drying, antibacterial Tri-chamois.





Tri-suit Lycra Man (56418)



This triathlon outfit combines a perfect fit with maximum freedom of movement. The suit is fitted with the ultra-light, quick drying and antibacterial Tri-chamois and a zip at the front. The round panel of the shorts is suitable for printing sponsor information.



**Running Singlet Dri Comfort
(52825)**

- Optimal breathing properties and a comfortable fit
- Maximum freedom of movement
- Manufactured in ultra-light, quick drying micro fabric

**Running Short Dri Comfort
(52724)**

- Ultralight shorts of quick drying Dri Comfort micro fabric
- Provided with a light inner short
- A cut-out allows the legs far greater freedom of movement



**T-Shirt sleeves Dri Comfort
(58218)**

- Optimal breathing properties and a comfortable fit
- Maximum freedom of movement
- Manufactured in ultra-light, quick drying micro fabric



Gamex Running Jacket (56410)

- Anatomically shaped with raglan sleeves and side panels
- manufactured from highly breathable Gamex
- Water repellent, windproof and can be folded easily and small
- Ventilating side panels



Tri-top Lycra (58307)



- Lycra top, with an aerodynamic fit. Retains its shape and is quick drying.
- Available in a ladies version



All Sport shorts (52815)



- Uni-sex Lycra shorts with a perfect fit and maximum freedom of movement
- Ultra-light and provided with a quick drying chamois.
- Printing of sponsor information possible on the side panel.



All Sport Tights (53006)



- Anatomically pre-shaped tights with a side panel for printing sponsor information.
- Quick drying and retains its shape
- Provided with an ankle trim and an elastic fastener.



Downhill Jersey (50619)



This downhill shirt is not only very comfortable to wear, it also removes perspiration and the special fit is completely geared to downhill use. The collar and sleeve trim are additionally strengthened to prevent 'flapping' during the descent.



American top (58226)

- Singlet with one back pocket
- Optimal breathing properties
- A comfortable cut ensures maximum freedom of movement



Swimming trunks (59206)

- Perfect fit, maximum freedom of movement
- Fitted with an ultra-light and quick drying chamois and an elastic fastener.



Mach 2 Speedsuit

A costume that has been made with just one objective: speed. Bio-Racer has made history with the Power 2. This high-end skating outfit is in fact a revolution in the area of aerodynamics and muscle support. The specific choice of fabrics is based on two principles.

- The muscle compression, which is generated by AeroCoat and Caro, in combination with the perfectly thought out cut of the costume ensures that the skater can, even must, remain longer in a skating position.

- The specially roughened structure of Caro and the carbon fibre structure of AeroCoat have a positive effect on the aerodynamics of the skater.





Speedsuit

A speed outfit with or without cap that is completely manufactured from the body elastic Caro. This ensures perfect balance between aerodynamics on the one hand and muscle support on the other.



Marathon Suit

Riding in circles, covering kilometres. During marathon skating you carry every discomfort far longer than you would wish to. For this reason the Bio-Racer R&D department has adjusted the cut of the marathon costumes. During long-distance races you can enjoy a high level performance and comfort.



Skeler Suit

Bio-Racer has also developed a costume specifically for the sport of in-line skating. This costume bears a close resemblance to the Bio-Racer aerodynamic outfits which have a high reputation in the cycling world. The same aerodynamic benefits, the same level of comfort. Available with (55208) or without flatlock (55108).





Thermo Bibtight

These warm dungarees are a perfect garment for the demanding skater. Perfect for the long ride. Due to the insulating capabilities the body retains heat far longer.





Zipper Tight Thermo

- Zips on the sides of the shorts
- Specially developed to quickly put on and take off
- Due to its insulating capabilities the body retains the heat far longer
- Available with or without braces, in 4 standard colours or with a printable side panel



Transotex-Thermo Skating Jack

- A really classic model, taken from our cycling collection
- High quality, functionality and flexibility
- Sleeves of Temp Control fabric provide a tight fit



Dolomiti Skating Jack

- Warm and flexible
- Completely manufactured from Temp Control
- Fits more closely than the Transotex skating vest
- Due to the thicker, roughened lining the body temperature is maintained for a longer period





Indoor Jersey Sleeveless (52987)



- Sleeveless Quadri shirt with ¾ zip
- Light, breathable and quick drying
- Perfect for indoor use

Indoor Jersey (52986)

- Quadri shirt with ¾ zip
- Light, breathable and quick drying
- Perfect for indoor use



Indoor Top Women (52985D)

- Sleeveless Lycra shirt with ¾ zip, fitted to the female anatomy
- Light, breathable and quick drying
- Perfect for indoor use





Indoor Jersey Women (52986D)

- Quadri shirt with $\frac{3}{4}$ zip, fitted to the female anatomy
- Light, breathable and quick drying
- Perfect for indoor use



Indoor Short (52886)

- Lycra indoor shorts with a printable Sport side panel and a indoor chamois
- Available with or without braces
- Also available for ladies (52886D)



Indoor Knicker Women (54206D)

- Lycra three-quarter length shorts with a printable Sport side panel and a indoor chamois, fitted to the female anatomy



T-Shirt

- Light and pleasant to wear
- Completely customizable
- Various colour combinations possible
- Choice of fabric, printing and/or embroidering on request



Polo

- Light and pleasant to wear
- Completely customizable
- Various colour combinations possible
- Choice of fabric, printing and/or embroidering on request



Training

- Top-of-the line tracksuit, the perfect choice before and after the top performance
- Completely customizable
- Various colour combinations possible
- Choice of fabric, printing and/or embroidering on request



Trainingshort

- Top-of-the line training shorts, the perfect choice before and after the top performance
- Completely customizable
- Various colour combinations possible
- Choice of fabric, printing and/or embroidering on request



Baseball Cap

- Fashionable, comfortable cap
- Completely customizable
- Various colour combinations possible
- Choice of fabric, printing and/or embroidering on request



Retro Training

- Tracksuit in retro style
- Completely customizable
- Various colour combinations possible
- Choice of fabric, printing and/or embroidering on request



Retro Sweater

- Hooded sweater in retro style
- Completely customizable
- Various colour combinations possible
- Choice of fabric, printing and/or embroidering on request

Visit www.bioracer.com for our standard collection

Windblock Winterhat (59502)

- Winter cap from Husky and Windblock
- Warm, insulating, moisture transporting
- Can also be used as neck protection
- Windblock band printed in the design of your club

Windblock headband (59613)

- Headband made from Windblock, printed in the design of your club
- Warm, insulating, moisture transporting effect, ear protection, velcro fastener

Team handschoenen (59094)

- Gloves with comfortable padding in the palm and a printable rear side
- Minimum quantity: 150 Pieces

Pirate Hat (59906)

- AIRTEX headscarf with rear fastening
- Moisture transporting effect
- Perfect in combination with a helmet

Sublimated legwarmers (59408)

- Leg pieces, adjusted to the colours of your team
- Sublimatable panel on the sides of the leg pieces
- Available in two versions, the light Caro summer model (59407) and a warmer Tempo Control variety (59408)

Sublimated armwarmers (59308)

- Arm pieces, adjusted to the colours of your team
- Sublimatable panel on the sides of the arm pieces
- Available in two versions; the light Caro summer model (59307) and a warmer Tempo Control variety (59308)





Sublimated Caro Overshoes
(59821)

- Light and aerodynamic overshoe from the very elastic Caro fabric
- Printable in your team's colours and logos

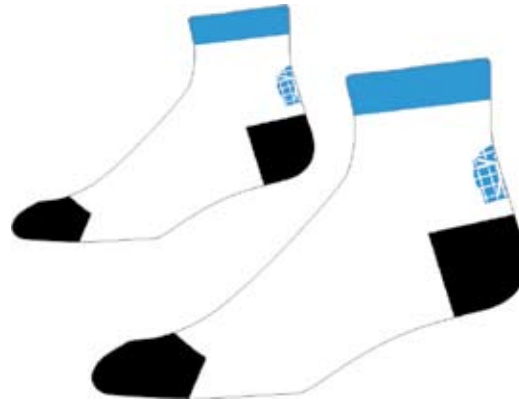

Team socks (59097)

- Coolmax socks with a weaving design in the colours and logo's of your Team.
- Minimum quantity: 100 Pieces

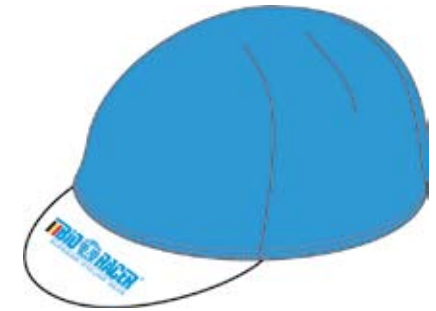

Team cap (50017)

- Coolmax socks with a weaving design in the colours and logo's of your Team.
- Minimum quantity: 100 Pieces

Visit www.bioracer.com for our standard collection



The highway to a top design

On the basis of the most requested and most beautiful designs Bio-Racer has developed a number of exclusive design templates, Prodesigns. This allows you to trace out your team clothing in a fast and simple manner.

The Prodesigns can be found on our website www.bioracer.com. You have the choice from twenty different designs with fixed areas for printing logos.

You can determine the colour combinations with a simple mouse click. Apart from white there is the possibility to choose one (for the cheapest range), two (most customary) or three (in the top range) additional base colours. Our representatives have catalogues available with the available colours.

Search through the templates for the pattern that best matches your profile and indicate which logos must be placed where.

Mail this design through to our designers, who will refine it further. Naturally we will send you the final design for approval.

Six to eight weeks after the first order your customized team clothing will be delivered.

This system can be used by both large as well as small teams. best quality – and the design, check your order during production and are the front line of our unparalleled service.



PRODESIGNS

→ ENGLISH → NEDERLANDS → FRANCAIS → DEUTSCH

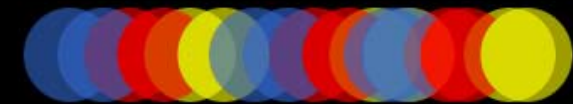

CUSTOMIZE YOUR TEAMCLOTHING

SITE REQUIRES A MINIMUM RESOLUTION OF 1024x768
BROADBAND CONNECTION - FLASH 8 PLUGIN

BIORACER.COM - PRODESIGNS

FLASH DEVELOPMENT AND DESIGN - WWW.VIER.BE





Bi-elastic in choices and service

Whether you have a large team, or even a very small one, a shop, company, or an upcoming event: Bio-Racer will always ensure that your clothing has exactly the appearance and functionality which you want to give it.

We distinguish ourselves from the competition in flexibility. We are the only sportswear manufacturer in Northern Europe which does everything under its own management, from design to delivery. Because of this we can perfectly and quickly anticipate all your requirements.

Naturally you may make a choice from our magnificent standard collections. Even there the hand of the innovator is clearly recognisable. The use of high-tech fabrics and ultramodern designs are the bias of our guarantees for maximum wearing comfort and a handsome look.

Anyone who wants to create customized team clothing, in a fast and simple way, can do that using our Prodesigns on www.bioracer.com. This programme is based on examples which can be copied.

Only when you are satisfied with a design that is completely in line with your needs, do we bring you into contact with the creative people in our design department. They will translate all your problems and preferences into colours and lines, to finally come to a unique, elegant and exciting design, which completely meets your profile.

Our customer-friendly representatives will always supervise the entire project. They advise you about the fabrics – which by the way are guaranteed to be of the best quality – and the design, check your order during production and are the front line of our unparalleled service.



World champions of delivery time

So many sportsmen and women, so many teams, so many tastes. That's why we gladly create for you a personal outfit which completely meets your specific requirements and wishes. Because Bio-Racer – as one of the few European sportswear manufacturers – does everything under its own management, nobody can deliver faster than us. Six to eight weeks from a standing start!

The design department consists of a number of creative young people, who together with you translate all your ideas and your profile into a practical design. The design is further developed until the clothing range of your dreams lies on the drawing table. Only after approval of the design does an order go into production.

The design is printed on sheets of paper in our own-silk screen printing facility, every colour separately. The ink on these sheets of paper is then sublimated into the white fabric at very high pressure and at high temperature. In this way the inks don't just lie on the fabric, they are absorbed into it, as it were. This increases the wearing comfort and the colourfastness and as consequence the life span of the garment.

For small quantities we work with digital printing.

The clothing manufacture takes place in our own workshop. In particular, the positioning of the chamois in the shorts receives special attention. Specially trained professionals ensure that your cycling wear will fit you like a glove.

The result is always a durable product in which the best fabrics are combined with a perfect finish. Our guarantee of thousands of miles of cycling pleasure.

Our experienced representatives – who almost all have a history in the peloton – advise you professionally about price, quality and technical possibilities. In human language. They answer all your questions in the same way. Furthermore they closely follow your order, from design to finished product.



Tested for you

Ferrari's Fiorano test circuit enjoys nearly as much fame in the motoring world as the brand with the rearing horse itself. Henceforth Bio-Racer also makes use of its own testing and training centre, in the Spanish town of Benicassim, 40 kilometres from Valencia.

Bio-Racer takes no chances before launching a new product. We insist that everything is comprehensively tested by cyclists from all target groups, from professional cyclists to touring cyclists, men as well as women, in all age and weight categories. Nothing is left to chance. We continue improving and testing and will only sleep soundly when the product is completely perfect.

History tells us that prominent 'thinkers' often follow the same thought processes. Bio-Racer also met kindred spirits in Spain. With the owners of a hotel chain with a great sporting heart. These people have given themselves the objective of offering their customers the optimal surroundings and facilities to practice their profession or hobby.

Stefan Everts' motor-cross school found a home here ten years ago. Amongst others, David Philippaerts, the new sensation in the motor-cross world, is one of the family in this hotel. Continuous heavy investments are made in the comfort of the guests and the care of his equipment. Even plans for an actual racing circuit are in an advanced stage.

Mountain bikers find no less than 500 kilometres of track in the neighbourhood and the road racer can choose between a billiard surface track along the coast or a demanding mountain ride with mountain tops of up to 1300 metres. This paradise for cyclists has been discovered in recent years by various top riders from the professional peloton and various teams come to prepare for the new season. Thousands of recreational cyclists follow in their wake.

At Benicassim we found the circumstances, an infrastructure and the mentality which is required to set up the test laboratory for all our innovations. We did that together with Ridley, the cycle manufacturer.

Incidentally, in cooperation with the De Toerist travel agency, Bio-Racer organizes cycling holidays and training sessions at this location.

