

E 9224-2886-11 H-A006



Thank you for purchasing the Minolta Dimâge Scan Dual2. The Dimâge Scan Dual2 AF-2820U is a dual format film scanner capable of scanning 35mm and, with the optional AD-10 APS Adapter, Advanced Photo System film.

This manual has been designed to help you understand the operation of your scanner. Please read this manual thoroughly to realize all the benefits of your scanner.

The instructions in this manual assume you have a working knowledge of the operating system for your computer (Macintosh OS, Windows 98, or Windows 2000) and its conventions. Familiarity with the mouse and standard operating system menus and commands is necessary before operating the driver software for the Dimâge Scan Dual2.

This manual does not instruct in the:

- basic use of personal computers.
- use of Windows 98, Windows 2000, or Macintosh OS.
- use of Adobe Photoshop, Paint Shop Pro, or Corel Draw.

The examples in this manual use Windows 98. The appearance of some screens may differ from the examples when using Windows 2000, or the Macintosh operating system.

Microsoft, Windows®, Windows 98®, and Windows 2000® are registered trademarks of the Microsoft Corporation.

Macintosh™, Apple®, and Power Macintosh® are registered trademarks of Apple Computer, Inc.

Adobe® and Photoshop™ are registered trademarks of Adobe Systems Incorporated.

Corel Draw™ is a trademark of the Corel Corporation.

Paint Shop Pro is the copyright of Met's Corporation.

Other corporate and product names are the trademarks and registered trademarks of their respective companies.

- Changes or modifications not approved by the party responsible for compliance could void the user's authority to operate the equipment.
- This manual may not be copied in part or whole without prior written permission from Minolta Co., Ltd. ©2000 Minolta Co., Ltd.
- Every necessary caution has been taken to ensure the accuracy of this instruction manual. Please contact us if you have any questions, find any errors, or notice missing information.
- Minolta is not responsible for loss, damage, or other results occurring during the operation of this product.



This mark certifies that this product meets the requirements of the EU (European Union) concerning interference causing equipment regulations. CE stands for Conformité Européenne.

Film Scanner: Dimâge Scan Dual2 AF-2820U



Tested to comply
with FCC standards.

FOR HOME OR OFFICE USE

This device complies with Part 15 of the FCC Rules. Operation is subject to the following conditions: (1) This device may not cause harmful interference, and (2) this device must accept any interference received, including interference that may cause undesired operation. To meet FCC regulations, the SCSI cables used with this scanner must be equipped with ferrite cores.

This Class B digital apparatus complies with Canadian ICES-003.

Cet appareil numérique de la classe B est conforme à la norme NMB-003 du Canada.

Tested by the Minolta Corporation 101 Williams Drive Ramsey, New Jersey 07446 USA

FOR PROPER AND SAFE USE

Please read and understand each caution before using this product.

WARNING

To avoid fire or electric shock:

- Use only within the voltage range specified on the back of unit.
- Do not expose this unit to liquids.
- Do not insert metal objects into this unit.
- Do not touch the AC power adapter unit, cord or plug if your hands are wet.
- Unplug this unit when it is not in use.

Improper use of the AC power adapter cord may result in fire or electric shock.

- Insert the plug securely into an electrical outlet.
- Do not pull on the AC power adapter cord. Grasp the plug when removing the AC power adapter cord from an AC outlet (mains).
- Do not scratch, twist, modify, heat, or place a heavy object on the AC power adapter cord.
- Do not connect the ground to a gas pipe, telephone ground, or a water pipe. Improper grounding can result in electric shock.



This product must have sufficient ventilation while in use. Blocked ventilation ducts may cause the unit to overheat, increasing the risk of fire.

- Do not use or store this product in dusty or very humid areas.
- This product should be operated in the upright position only. Do not stack any objects on this product.

If there is smoke, a strange smell, or any other unusual conditions, shut down and unplug the unit, then contact a Minolta Service Facility.

Do not attempt to disassemble this product. It contains high-voltage circuits. Take the product to a Minolta Service facility for repairs.



CAUTION

Unexpected damage may occur if this unit is left unattended near young children.

PACKAGE CONTENTS

The following contents should be included in this package

1. Minolta Dimâge Scan Dual2
2. 35mm Slide holder (FH-U1) and Negative holder (SH-U1)
3. USB cable
4. AC power adapter (AC-U1, AC-U2 or AC-U3)
5. CD ROM for Dimâge Scan Dual II
6. CD ROM for Photoshop LE
7. Warranty card
8. Quick Reference Guide

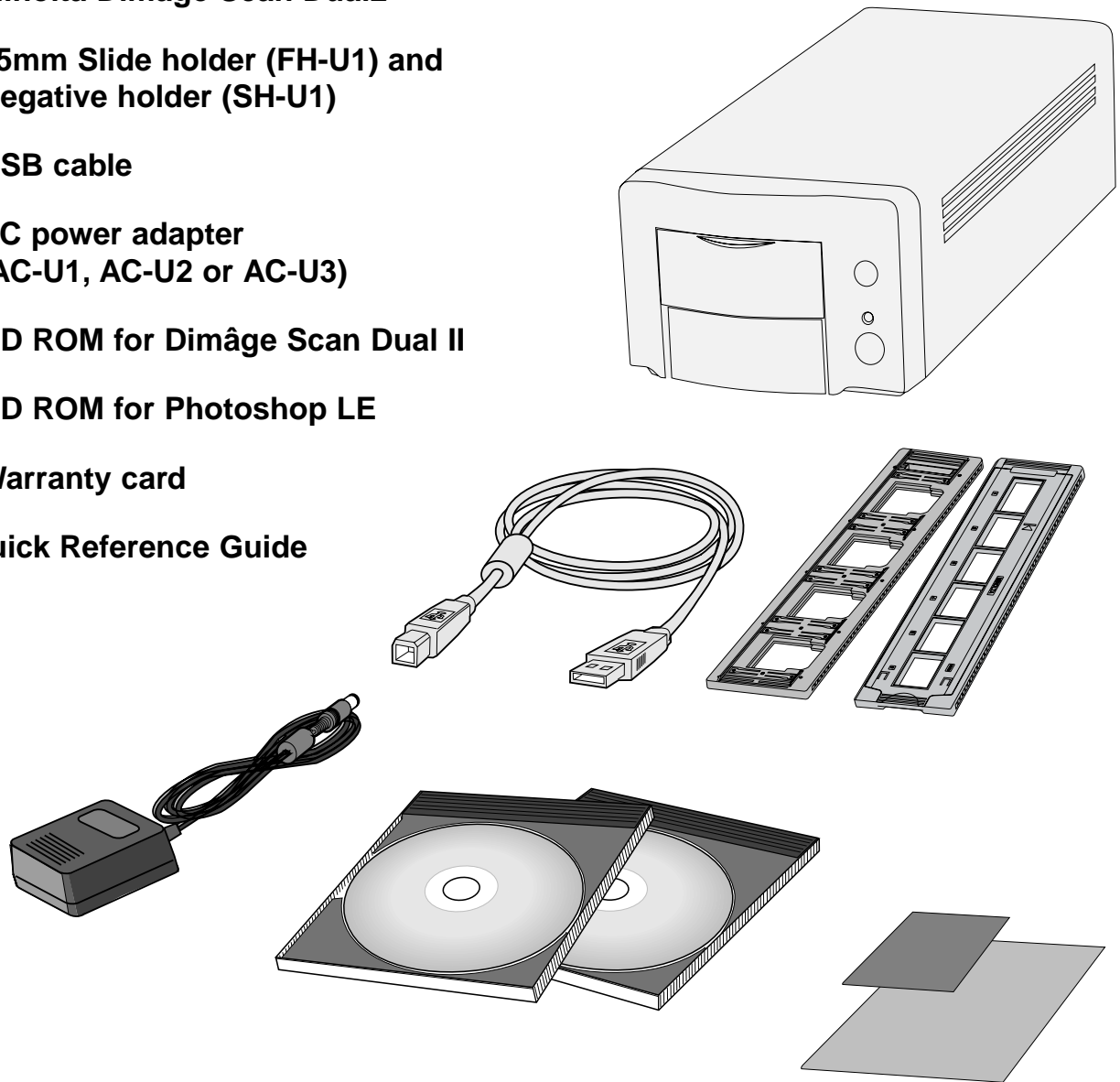

Software Registration

Please register this software before using it...

Once registered, you will receive technical support, software upgrade and product information. Complete and return the enclosed Product & Software Registration form after detaching it from the Warranty. No postage is necessary.

- The information you provide is confidential and will only be used by Minolta Customer Service and Product Research & Development.

The display indications may differ depending on your PC's preferences and a using version of the scanner driver.

The details of the contents are described on the following page.

Overview

 **9**

This section describes the required system and the names of the parts.

Scanner setup

 **13**

This section describes how to set up of the scanner.

Easy Scan Utility

 **23**

This section describes how to load the film holder and perform the Minolta Easy Scan Utility.

Index Scan

 **35**

This section describes how to perform the index scan.

Preview scan

 **49**

This section describes how to perform the preview scan.

Image correction

 **63**

This section describes how to perform the final scan and save it.

Final scan

 **83**

Read this section if necessary.

Appendix

93

TABLE OF CONTENTS

	FOR PROPER AND SAFE USE	3
	PACKAGE CONTENTS	4
	SCANNER – NAMES OF PARTS	9
	SYSTEM REQUIREMENTS – PC / AT	10
	SYSTEM REQUIREMENTS – MACINTOSH	11
SCANNER SETUP	SCANNER SETUP FLOW	13
	INSTALLING THE PHOTOSHOP LE – WINDOWS	14
	INSTALLING THE PHOTOSHOP LE – MACINTOSH	15
	INSTALLING THE SOFTWARE – WINDOWS	16
	INSTALLING THE SOFTWARE – MACINTOSH	19
	CONNECTING THE HARDWARE	21
EASY SCAN UTILITY	EASY SCAN UTILITY FLOW	23
	LAUNCHING Easy Scan Utility	24
	WINDOWS 95/WINDOWS 2000 – Starting up the utility software	24
	MACINTOSH – Starting up the utility software	24
	Easy Scan Utility Window	25
	The Easy Scan Utility Window – Name of parts	25
	LOADING THE FILM HOLDER	26
	Loading the 35mm Negative Film Holder – FH-U1	26
	Loading the Slide Mount Holder – SH-U1	27
	APS ADAPTER (OPTIONAL)	28
	Names of Parts	28
	Loading the APS Adapter	28
	INSERTING THE FILM HOLDER INTO THE SCANNER	29
	Scanning with the FH-U1 35 mm film or SH-U1 slide film holder	29
	INSERTING THE APS ADAPTER	30
	SPECIFY THE FILM TYPE	31
	EASY INDEX SCAN	32
	Setting the usage	32
	Image Correction	32
	Rotate	32
	SPECIFY THE JOB TYPE/SAVING	33
	SCANNING FLOW	35
	LAUNCHING THE SOFTWARE	36
	Launching the TWAIN Driver – Windows	36
	Launching the Plug-in – Macintosh	37
	Launching the Utility Software	38
	MAIN WINDOW – Name of parts	38
	MAIN window	38
	The Command window part – Name of parts	38
	SETTING THE PREFERENCES	39
	SETTING THE FILM TYPE	41
INDEX SCAN	INDEX SCAN – NAME OF PARTS	42
	The Index tab part – Names of Parts	42
	INDEX SCAN	43
	Index scan	43
	Changing the Window Size	43
	SCANNING THE IMAGE	44
	Rotating the Index Frames	45
	Reversing Frame order	45
	SAVING INDEX SCAN IMAGE	46
	SAVING INDEX IMAGE FILE	47
	LOADING INDEX IMAGE FILE	48

PREVIEW	SCANNING FLOW49
SCAN	PRESCAN50
	The Prescan tab part – Names of parts50
	ORIENTING THE IMAGE52
	Rotate52
	Flip53
	Full screen view54
	Magnifying or Reducing the View54
	Scroll55
	AUTO-EXPOSURE LOCK56
	Setting AE-Lock56
	Cancelling AE-Lock56
	AE AREA LOCK57
	FOCUS – POINT AF58
	Focus58
	POINT AF58
	FOCUS – MANUAL59
	MANUAL FOCUS59
	CROPPING THE IMAGE60
	Auto Cropping60
	Cropping60
	PRESCAN AND IMAGE CORRECTION61
	APS formats; C, H and P (APS only)62
	RGB/CMY information62
	Displaying Frame number62
IMAGE	IMAGE CORRECTION FLOW63
CORRECTION	IMAGE CORRECTION64
	The Image Correction tab part – Names of parts64
	AUTO IMAGE CORRECTION65
	TONE CURVES/HISTOGRAM66
	The Tone Curves and Histogram Dialog Box – Names of Parts66
	Correcting the Tone Curves67
	Changing Tone Curves by Freehand67
	Correcting the Histogram68
	Setting the White or Black points69
	Viewing the Histogram of Images After Making Corrections70
	Auto Setting70
	Reset70
	BRIGHTNESS/CONTRAST/COLOR BALANCE71
	The Brightness, Contrast and	
	Color Balance Correction Dialog box – Names of parts71
	Auto Setting72
	Reset73
	HUE/SATURATION/LIGHTNESS73
	The Hue, Saturation,	
	Lightness Correction Dialog box – Names of parts73
	Auto Setting74
	Reset74
	VARIATION CORRECTION75
	The Variation Dialog Box – Names of Parts75
	Selecting the Correction Item75
	Color Balance Correction76
	Brightness & Contrast Correction76
	Saturation Correction77
	Changing the Amount of Correction Step77
	Reset77
	SNAPSHOT78
	Storing in the Snapshot Display Area temporarily78
	Displaying the image stored temporarily as a prescan image78
	CANCELLING IMAGE CORRECTION79
	Cancelling the Image Correction79
	Redo the Correction79
	Delete the Image Correction79

TABLE OF CONTENTS

	FULL-SCREEN VIEW	.80
	Full-Screen View	.80
	Checking the Correction Result While Lining Up Images	.80
	JOB SAVE/JOB LOAD	.81
	Saving Image Correction Job	.81
	Loading Image Correction Job	.82
FINAL	FLOW	.83
SCAN	SCAN SETTINGS	.84
	The Scan Settings part window – Names of parts	.84
	CREATING / DELETING JOB FILES	.87
	Creating a Job	.87
	Deleting a Job	.87
	SCAN JOB TYPE	.88
	FINAL SCAN	.89
	Twain Driver / Plug-in Software	.89
	Utility Software	.89
	NAVIGATION	.90
	The Navigation Dialog box – Name of parts	.90
	Navigation Menu	.91
	Saving, Selecting and Deleting a Navigation Setting	.92
APPENDIX	APPENDIX	.93
A	COLOR MATCHING	.94
	Output color space setting	.95
	ICC profile setting	.95
	SCAN JOB FILE LIST – 35mm	.96
	SCAN JOB FILE LIST – APS	.98
	GLOSSARY	.99
	TROUBLE SHOOTING	.101
	SPECIFICATIONS	.102
	USER TECHNICAL SUPPORT	.103
APPENDIX		
B	SOFTWARE-INSTALLATION – WINDOWS	
	When the “Add New Hardware Wizard” window is displayed	.104
	When the PC does not recognize the Dimâge Scan Dual II	.104
	When the Dimâge Scan Dual II driver software does not start up	.106
	WINDOWS 2000	.108
	CONTACTING MINOLTA	.108

SCANNER – NAMES OF PARTS

1. Eject button
2. Front door
3. Mark of 35 mm Film
4. Mark of APS cassette
5. Indicator lamp
6. Power switch
7. USB port
8. DC power input plug

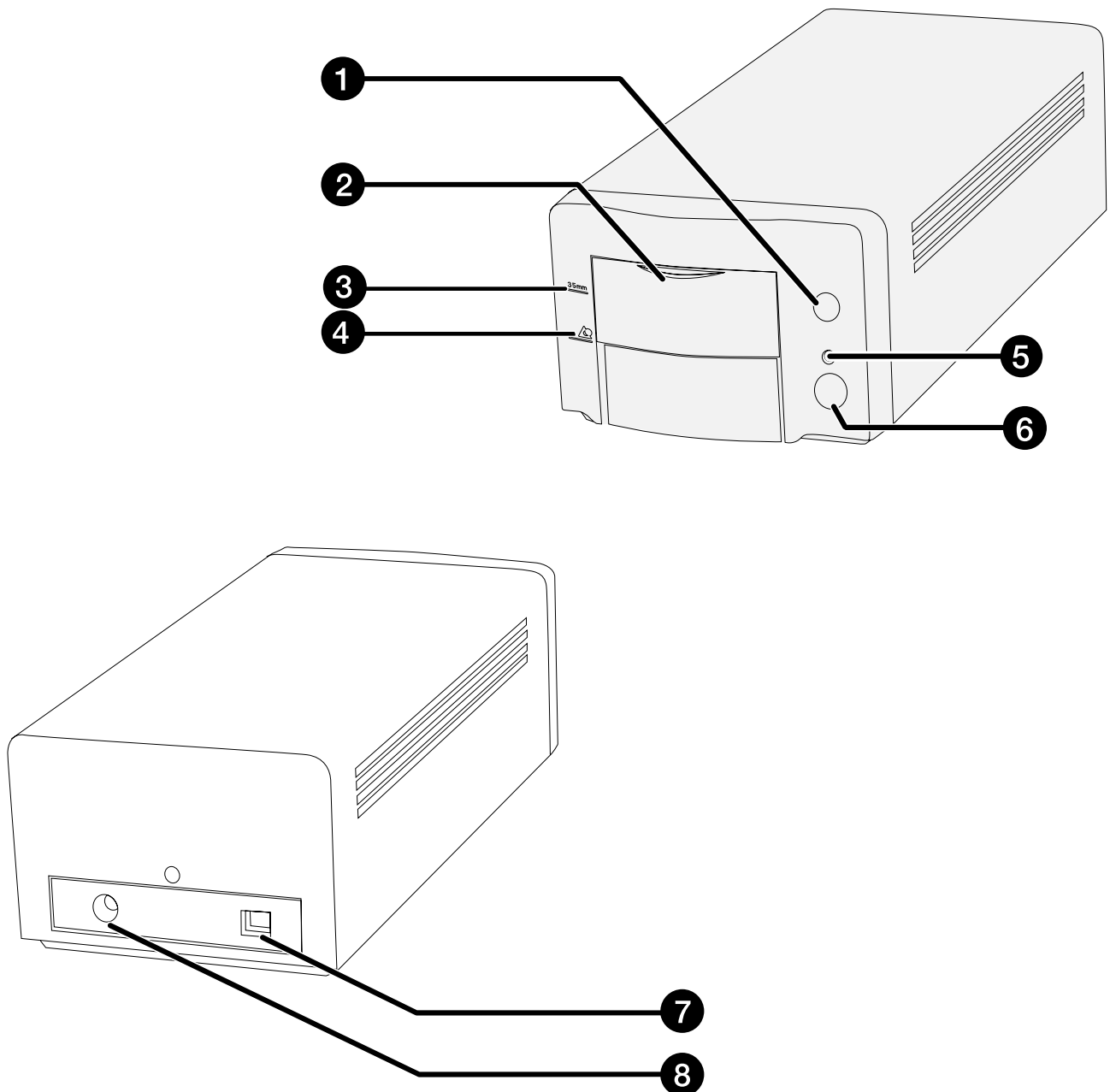

SYSTEM REQUIREMENTS – PC/AT

CPU: IBM PC/AT compatible with an Intel Pentium or later processor or better.
An Intel Pentium or later when Windows 98 or Windows 2000 is installed.

- Support cannot be provided for custom or home built machines.

Operating System: Windows 98, or Windows 2000 Professional.

Memory: A minimum of 32 MB RAM.

Hard Disk Space: 90 MB of available hard disk space.

Interface: USB Port

Monitor: XGA (1024 x 768) or better. VGA (640 x 480) can be used.

Other: TWAIN driver is compatible with Photoshop Ver.3.05, Ver.4.0.1, Ver.5.0.2, and Ver.5.5.
Photoshop LE
Paint Shop Pro 5.01, Corel Photo Paint 8.

SYSTEM REQUIREMENTS – MACINTOSH

CPU: Power PC

Operating System: Mac OS 8.5 – 9

Memory: A minimum of 16 MB application RAM in addition to the requirements for the Mac OS and Adobe Photoshop™

Hard Disk Space: 90 MB of available hard disk space.

Monitor: 19 inch (1024 x 768) monitor or better.
13 inch (640 x 480) monitor capable of displaying 32,000 colors.

Interface: USB port

Other: Plug-in is compatible with Photoshop Ver. 3.05, Ver. 4.01, Ver. 5.02 and Ver. 5.5.
Photoshop LE

SCANNER SETUP

SCANNER SETUP FLOW





CAUTION – Before installing

- Please remove or disable any antivirus system extensions before launching this installer. These extensions may conflict with the operation of the installer. Replace or re-enable them when the installation is complete.

This manual describes how to install Adobe Photoshop LE as the image editing application. The commands, the displays or the operations may differ when using another image editing application. In this case, refer the instruction manual of the application you use. And if you have never used the image editing application, install the Photoshop LE before installing the supplied software.

Installing Photoshop LE – Windows®98/2000

This installation instruction assumes that the drive D or C is a CD-ROM or a hard disc drive respectively.

- 1. Turn on the PC and start up the Windows®98/2000.**
- 2. Insert the Photoshop LE CD-ROM into the CD-ROM drive.**
- 3. Select Start > Run... and input “D:\ENGLISH\install.wri” in the Name (o): box and then click on OK.**
 - “Read Me file” will appear. Read the content and confirm it.
- 4. Select Start > Run... and input “D:\ENGLISH\PHOTOSLE\Setup.exe” in the Name (o): box and then click on OK.**
 - Perform the installation according to the instructions displayed in the window.
- 5. Select “United States/Canada” in the Select Country window.**
 - Perform the operation according to the instructions displayed in the window.
- 6. Select the following either one in the install dialog box.**
 - When installing the most typical options, select “Typical”.
 - When installing the only options you need, select “Compact”.
 - When selecting the options you install, select “Custom”.
 - Perform the installation according to the instructions displayed in the window.
- 7. Input your name, company name and the serial number printed on the package of the CD-ROM accurately in the User Information window.**
- 8. After the installation is completed, restart your PC.**

Installing Photoshop LE -- Macintosh

1. **Insert the Photoshop LE CD-ROM into the CD-ROM drive.**
2. **Double-click on the installer icon.**
 - The install program will start.
3. **Click on “English” and read “Install” and confirm the content.**
4. **Perform the installation by following the instructions described in “Install” file.**
5. **Select the following either one in the install dialog box.**
 - When installing the most typical options, select “Easy”.
 - When selecting the options you install, select “Custom”.
 - Perform the installation according to the instructions displayed in the window.
6. **When starting up Photoshop LE, input your name, company name and the serial number printed on the package of the CD-ROM accurately in the Setup window.**
7. **After the installation is completed, restart your PC.**

INSTALLING THE SOFTWARE – WINDOWS

WINDOWS 98/WINDOWS 2000

Dimâge Scan Dual2 for Windows Setup installs the Twain and Twain_32 driver software into the drive and folder you select.

- The appearance and/or wording of some dialog boxes may vary depending on the version of Windows running on your machine.
- These installation instructions assume drive D is the CD-ROM drive.

1. Turn on the scanner, then turn on the PC.
2. Start the Windows operating system.

This step varies with your specific operating software...

Windows 98

- The Device Wizard dialog box will appear.



then click on Finish.

- This dialog box may appear several times.

3. Insert the Dimâge Scan Dual2 CD-ROM into the CD-ROM drive.

4. Select **R**un from the Start menu.

5. Select **D:\Driver\English\Setup.exe** from the Open drop-down list, then click on **O**K.

- If your CD-ROM drive is not the D drive, replace the D with the appropriate designation for your CD-ROM drive.

The Run dialog box will appear.

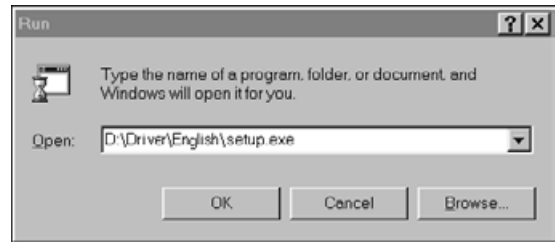

6. Click on **N**ext.

The installer flash will appear.



7. After reading the agreement, click on **Y**es.

- If you do not agree to the conditions stated in the End-User License Agreement, click on No and the software will not be installed.

The Software License Agreement will appear.

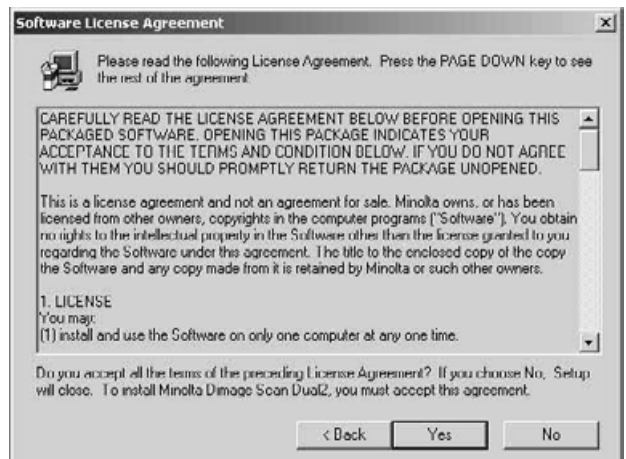

The Choose Destination Location dialog box will appear.

8. Click on **B**rowse to select another destination directory...

- An install directory and path can also be entered directly into the install path list box.

then click on **N**ext.



9. Choose either Typical or TWAIN Files install, then click on **Next**.

The Setup Type dialog box will appear.

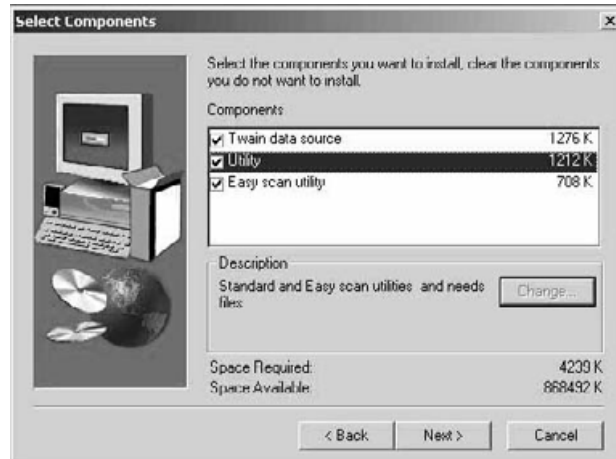

10. Click on **Next**.
 • Setup will begin.

The Select Program Folder dialog box will appear.

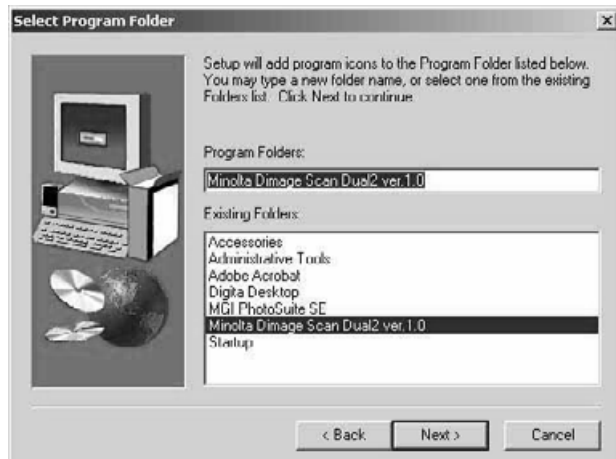

11. Click on **Close**.

The Setup Successful dialog box will appear.





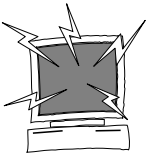

12. Click on **Finish**.

INSTALLING THE SOFTWARE – MACINTOSH



Please remove or disable any antivirus system extensions before launching this installer. These extensions may conflict with the operation of this installer. Replace or re-enable them when installation is complete. Hold the shift key down during startup to disable the extensions.

1. Turn on the Dimâge Scan Dual2, then turn on your Macintosh.
2. Quit any open applications.
3. Insert the Dimâge Scan Dual2 CD-ROM into the CD-ROM drive.
 -  will appear on the desktop.
4. Double-click on .
 - The driver folders will appear.
5. Double-click on Driver folder.
 - The language folders will appear.
6. Open the English language folder, then double click on the Dimâge Scan Dual2 Installer.
 - The installer's start-up screen will appear.
7. Click on  .

8. Click on  .
 - If you do not agree to the conditions stated in the End-User License Agreement, click on Decline and the software will not be installed.

The End-User License Agreement will appear.

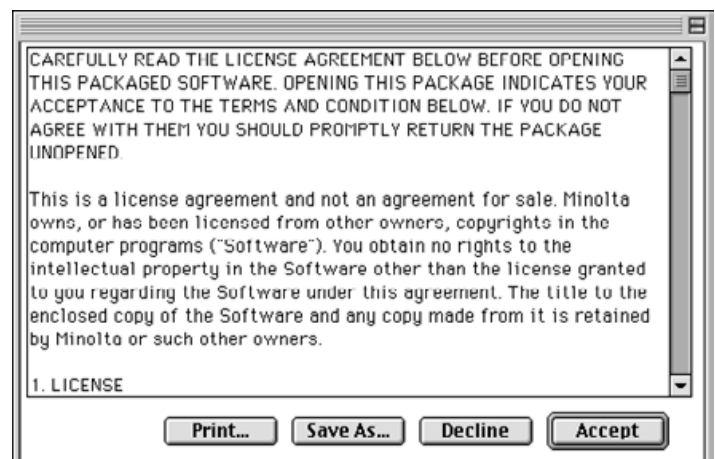

The following dialog box will appear.

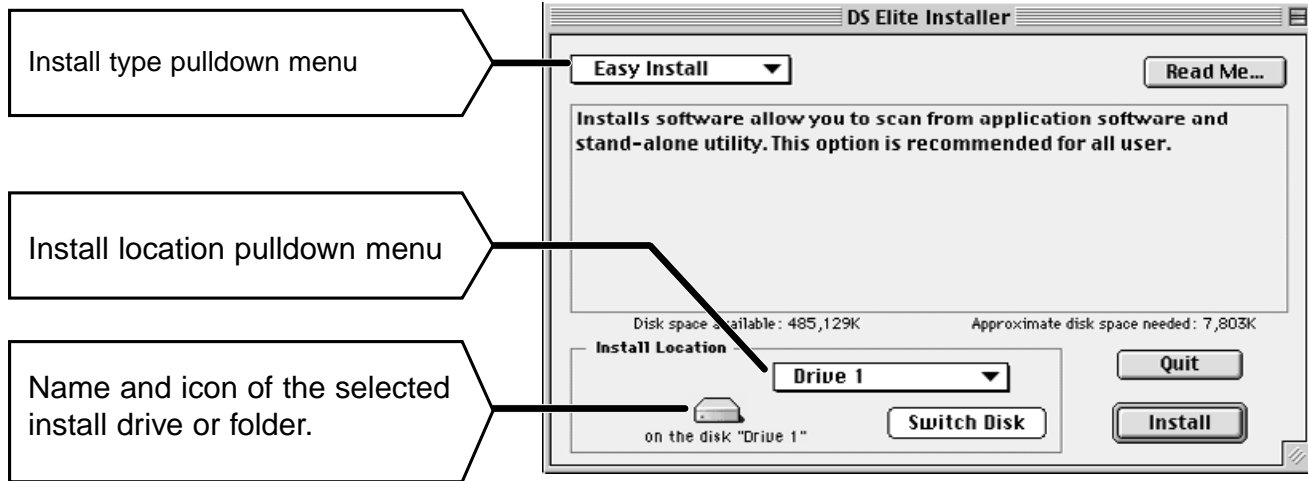

9. Select the install drive (or folder) and type from the pulldown menus.

- You can also click on  to select an install drive.

10. Click on .

The following message appears when the installer is finished.

11. Click on .

- The software will be installed in a new folder titled Dimâge Scan Dual2.
- If Easy Install was chosen, the Dimâge Scan Dual2 folder will contain the following items: DS_Dual2 Utility, DS_Dual2 Plug-in, and Read Me file.
- Your Macintosh will automatically restart.

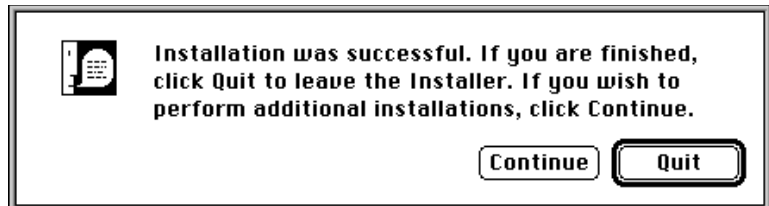

12. Drag the DS Dual2 Plug-in to the Import/Export folder in the Adobe Photoshop Plug-ins folder.

CONNECTING THE HARDWARE

Connecting the AC power adapter and the USB Cable.

This scanner has been packaged with the USB cable and AC power adapter.

1. Plug the AC power adapter cord into the scanner's AC socket, then plug it into a grounded outlet.

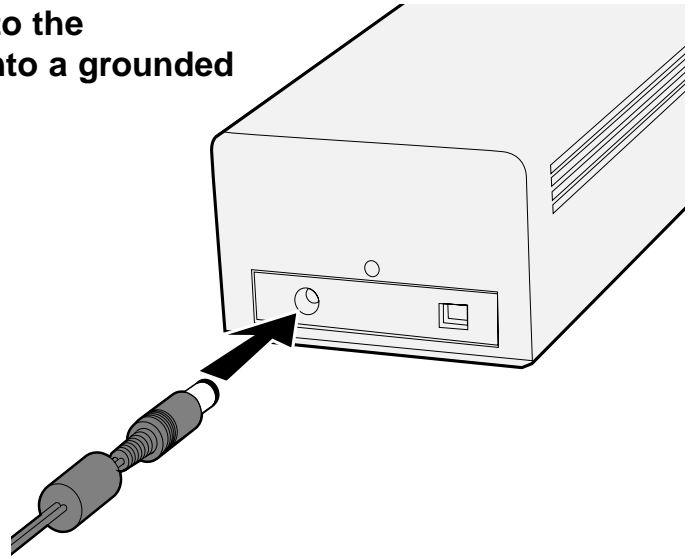

2. Connect one end () of the USB cable to either USB port on the back of the scanner.

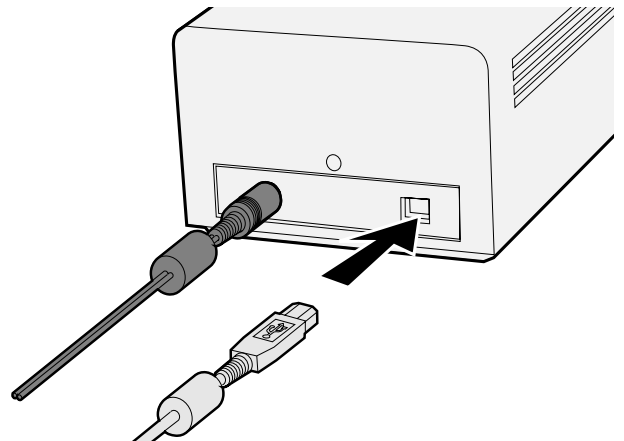

Continued on the following page

3. Connect the other end of the USB cable () to the USB port on the computer or the USB Hub terminal.

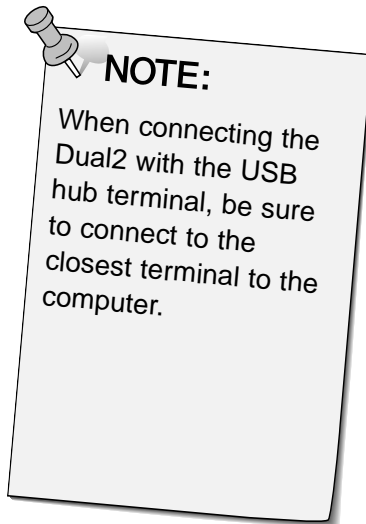
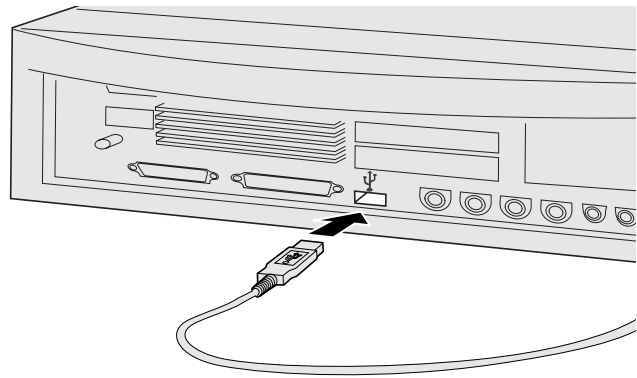

Example:
Connect the USB Hub terminal

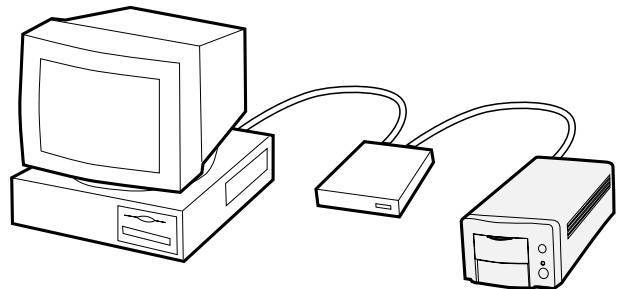

EASY SCAN UTILITY

EASY SCAN UTILITY FLOW

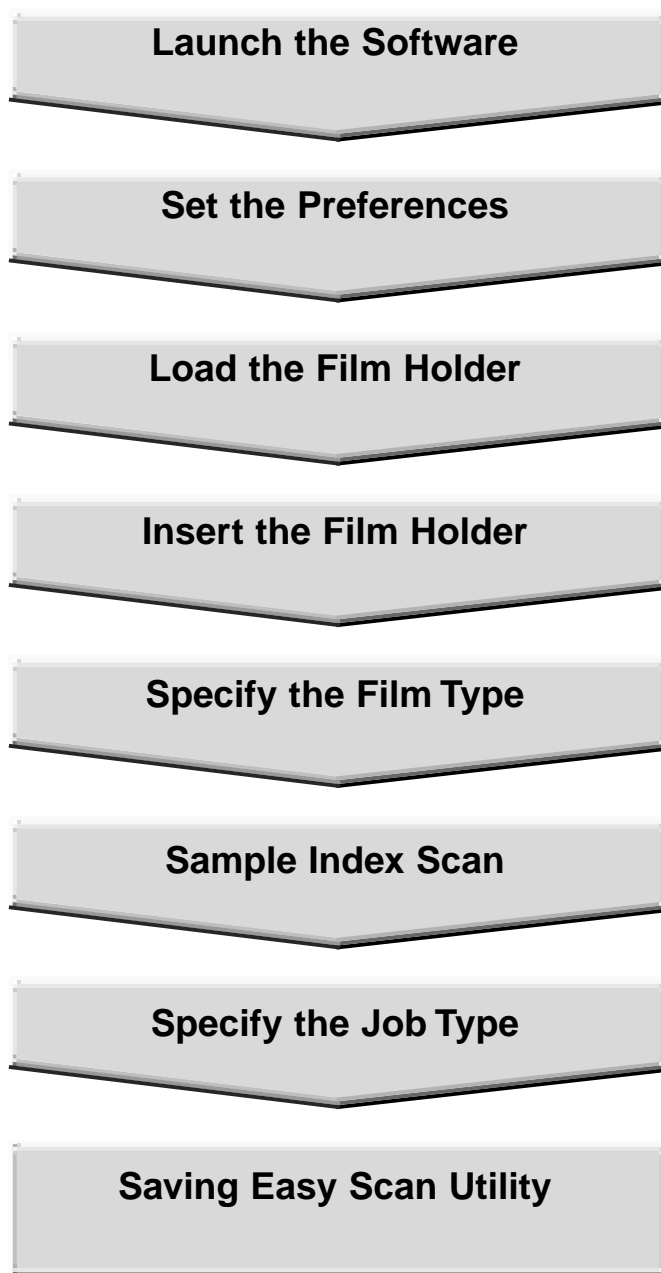

LAUNCHING EASY SCAN UTILITY

WINDOWS 98/WINDOWS 2000

Starting up the utility software

The Minolta Easy Scan Utility can be performed by using the utility software.

1. **After performing steps 1 and 2 on page 36, select Start > Program (P) > Minolta Dimâge Scan Dual2 ver.1.0 > EasyScan.**
 - The software starts up and the Easy Scan Utility window will appear.

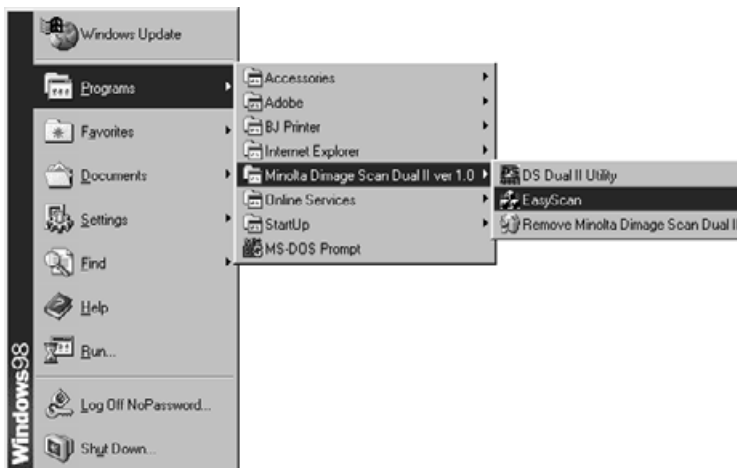

MACINTOSH

Starting up the utility software

The Minolta Easy Scan Utility can be performed by using the utility software.

1. **After performing steps 1 and 2 on page 36, double-click on the Dimâge Scan Dual2 ver. 1.0 folder and then double-click on EasyScan.**
 - The software starts up and the Easy Scan Utility window will appear.

Easy Scan Utility Window

While the Minolta Easy Scan Utility software is functioning, the following window is displayed.

The Easy Scan Utility Window – Name of parts

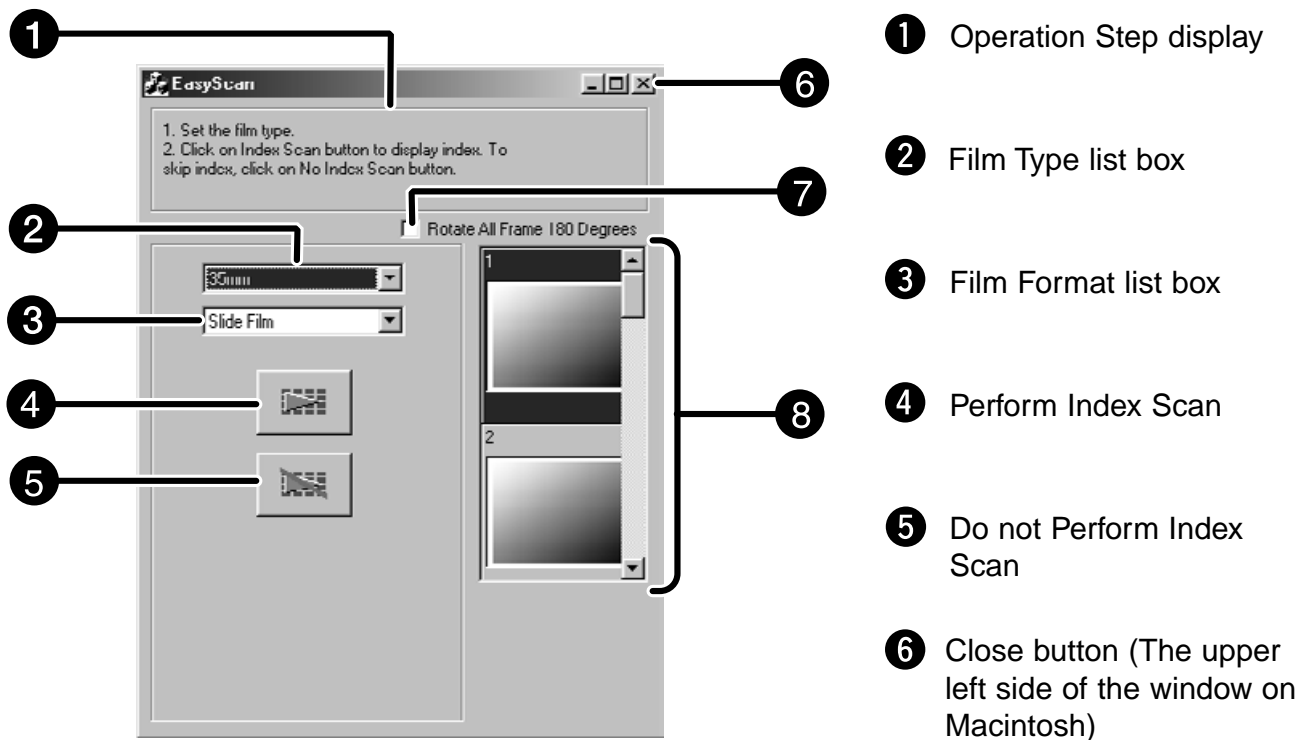

- 1 Operation Step display
- 2 Film Type list box
- 3 Film Format list box
- 4 Perform Index Scan
- 5 Do not Perform Index Scan
- 6 Close button (The upper left side of the window on Macintosh)

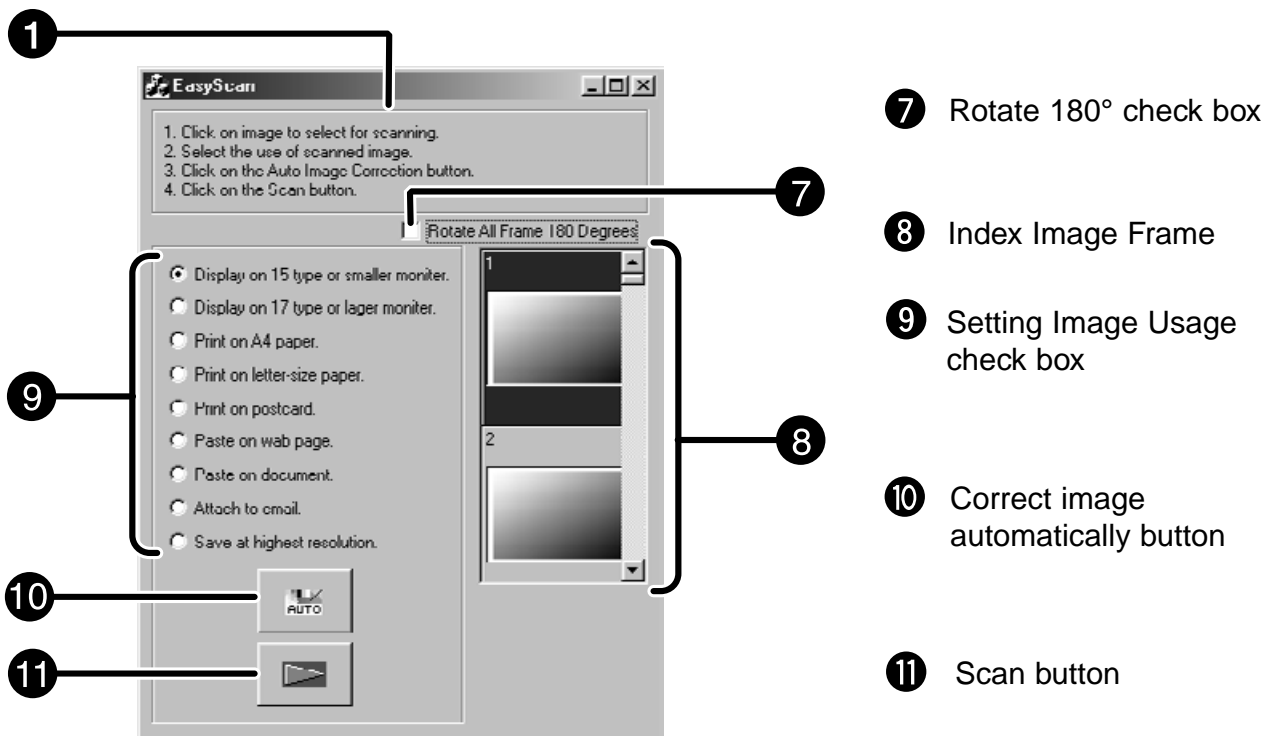

- 7 Rotate 180° check box
- 8 Index Image Frame
- 9 Setting Image Usage check box
- 10 Correct image automatically button
- 11 Scan button

LOADING THE FILM HOLDER

Using the included 35mm negative and slide holders, the Minolta Dimâge Scan Dual2 can scan mounted or unmounted...

- 35mm color negatives
- 35mm color slides
- 35mm black & white negatives
- 35mm black & white positives

APS (Advanced Photo System) negatives and slides can also be scanned using the optional AD-10 APS Adapter. See page 28.

Loading the 35 mm Negative Film Holder – FH-U1

1. Open the film cover on the 35 mm negative film holder by lifting the film number "6" side of the film cover.

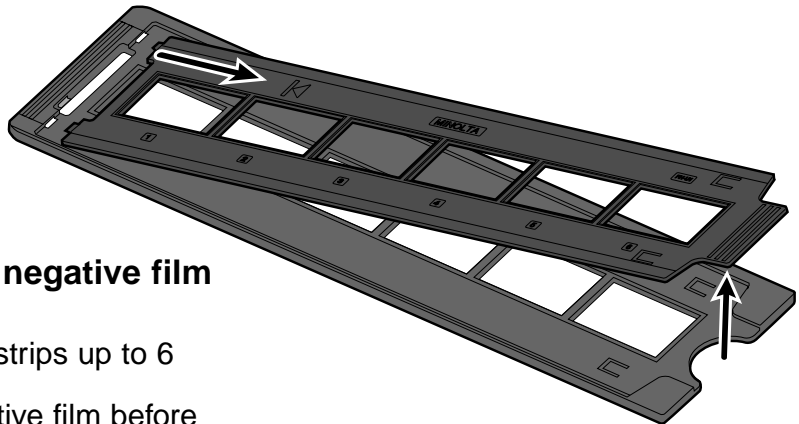

2. Place the film in the 35 mm negative film holder emulsion side up.

- The film holder will accept film strips up to 6 frames long.
- Brush dust off the 35 mm negative film before placing it into the film holder.

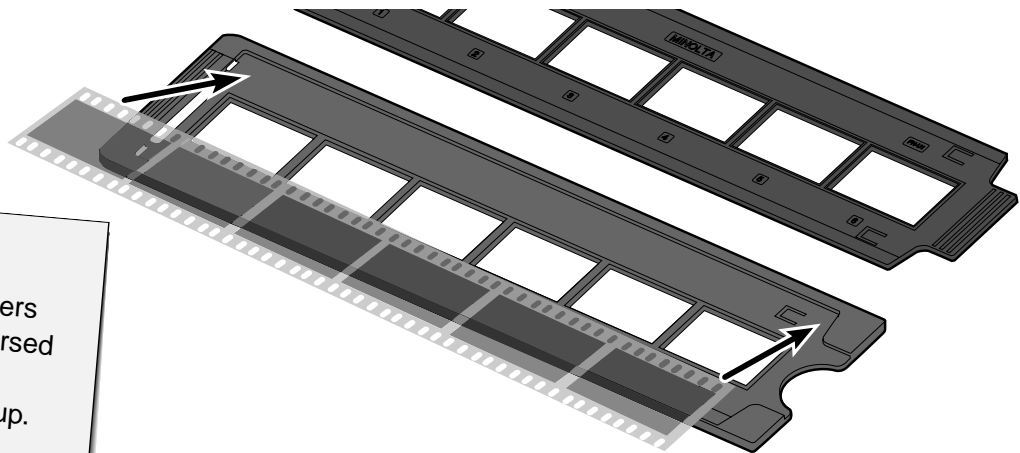

NOTE:

The frame numbers and text are reversed when the film's emulsion side is up.

3. Align the frames within the scanning windows.

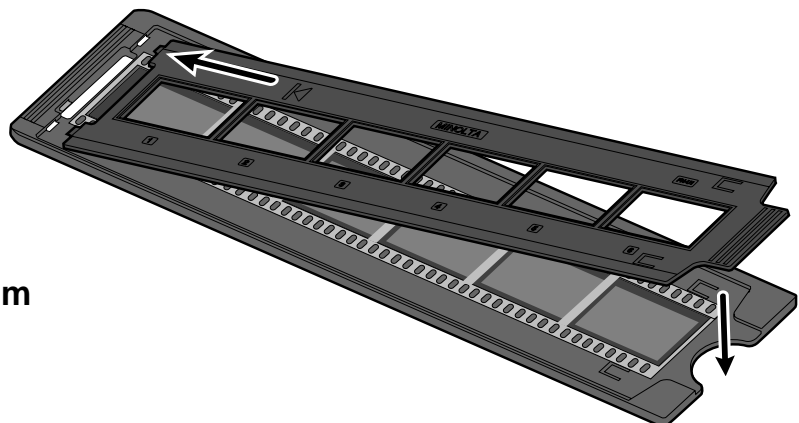

4. Snap the 35 mm negative film holder closed.

Loading the Slide Mount Holder – SH-U1

1. Insert slides into the slide mount holder emulsion side up.

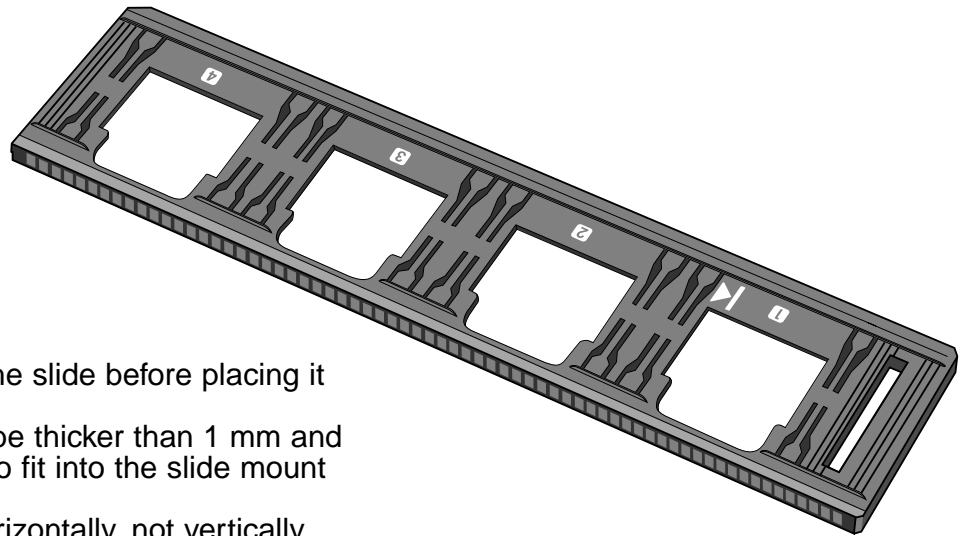

- Brush dust off the the slide before placing it into the film holder.
- Slide mounts must be thicker than 1 mm and thinner than 2 mm to fit into the slide mount holder.
- Orient the slides horizontally, not vertically.

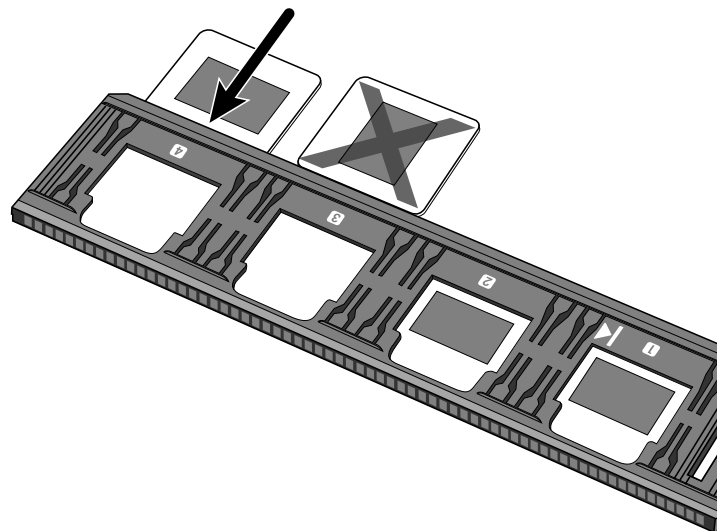
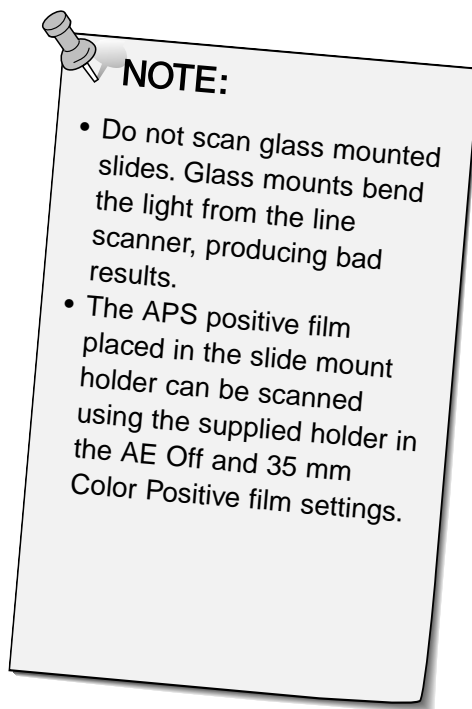

APS ADAPTER (OPTIONAL)

The AD-10 APS Adapter is an optional accessory. The Dimâge Scan Dual2 can not scan Advanced Photo System film (IX-240 type) without the AD-10 APS Adapter.

Names of Parts

- 1 Film-chamber door
- 2 Film-chamber release
- 3 Scanner contacts*

* Do not touch

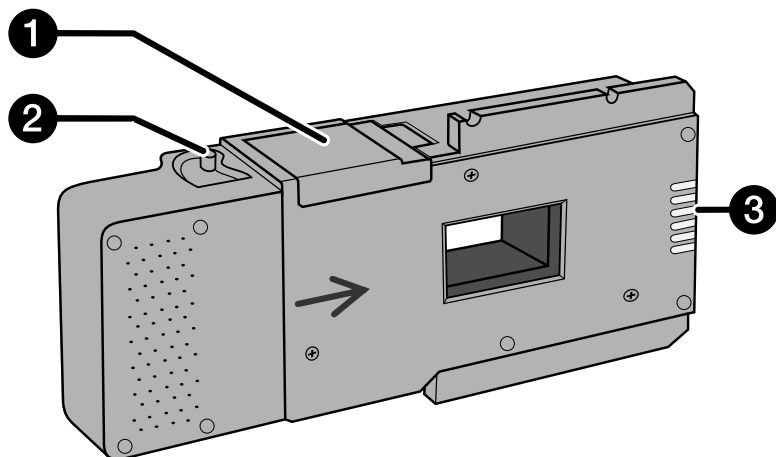

Loading the APS Adapter

1. Slide the film-chamber release as shown.

- The film-chamber door will open.

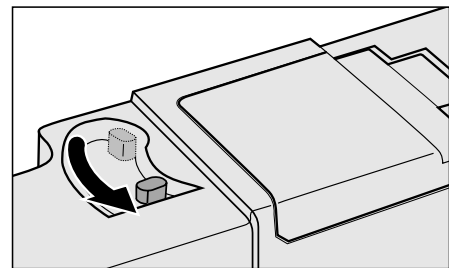

2. Insert the film cassette into the film chamber with the VEI on top.

- Only load cassettes with the ■ mark current.

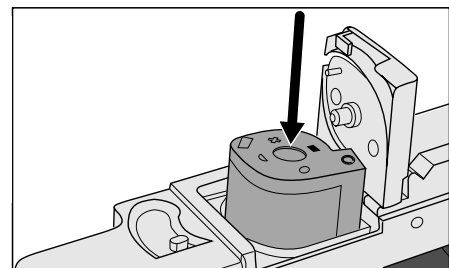

3. Close the film-chamber door.

- The film-chamber door will not close if the ■ mark is not current. Forcing the door shut could damage the cassette.

INSERTING THE FILM HOLDER INTO THE SCANNER

During the start-up time, the indicator lamp will blink. DO NOT insert the film holder into the film slot until the indicator lamp is steady.

Scanning with the FH-U1 35 mm film or SH-U1 slide film holder

1. Open the scanner lid by pushing it down to the 35 mm mark 35mm .
2. Be sure that the white arrow mark on the 35 mm film or slide film holder is facing up and then insert the 35 mm film or slide film holder into the scanner up to the arrow mark.

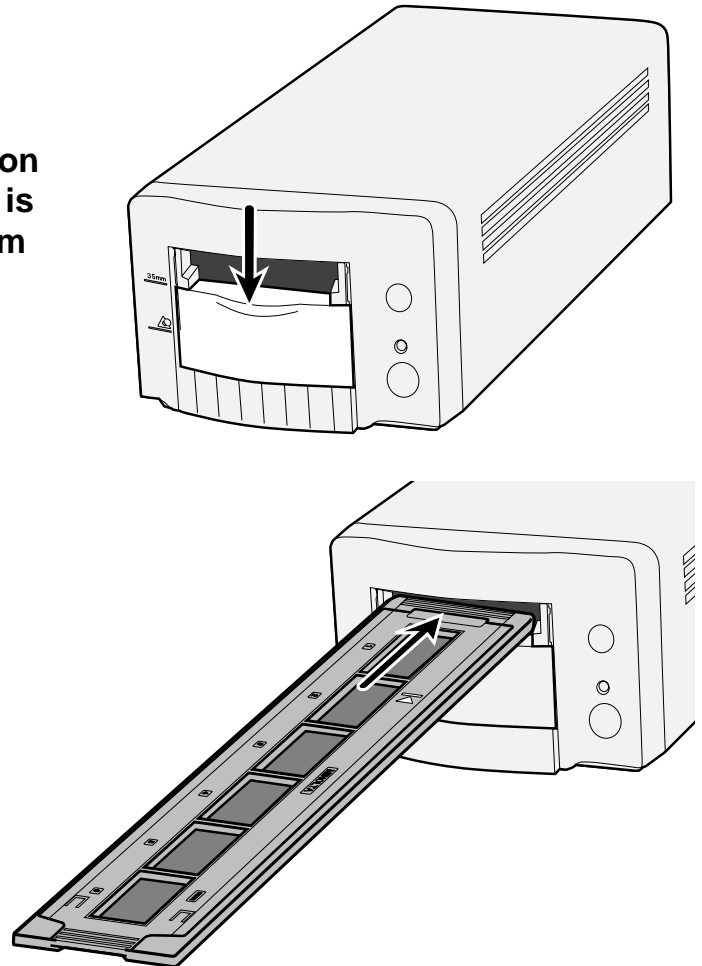

INSERTING THE APS ADAPTER

1. Open the scanner lid by pushing it down to the APS mark .

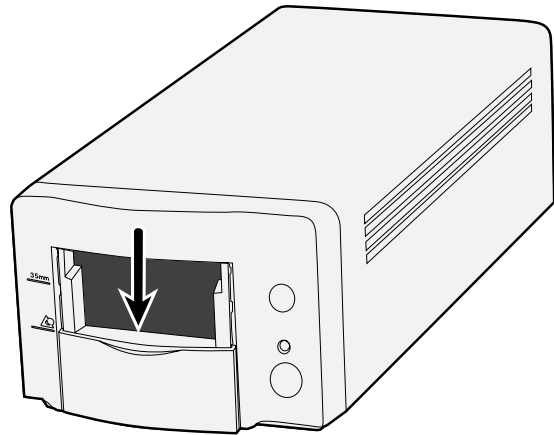

2. Be sure that the arrow mark on the APS adapter is facing up and then insert the APS holder into the scanner until the holder stops.

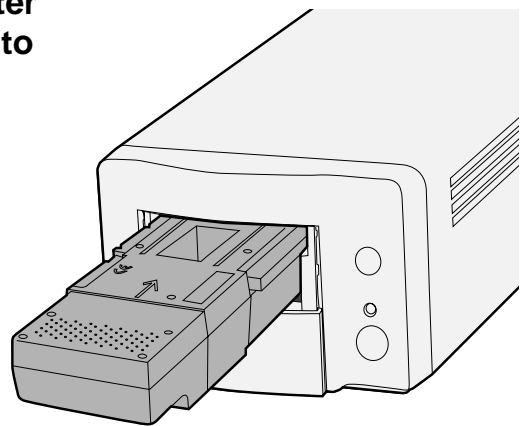

SPECIFY THE FILM TYPE

Selecting the film type

- 1 Select the film format to be scanned in the Main window.
- 2 Select the film type.
 - The index tab is selected and the index window will appear.

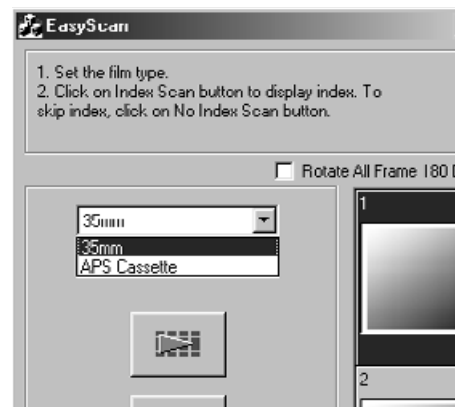

EASY INDEX SCAN

1. Select whether the index scan should be performed or not.

- When 'Perform the index scan' is selected, the index scan starts. When 'Not Perform the index scan' is selected, the window changes to the scan window.

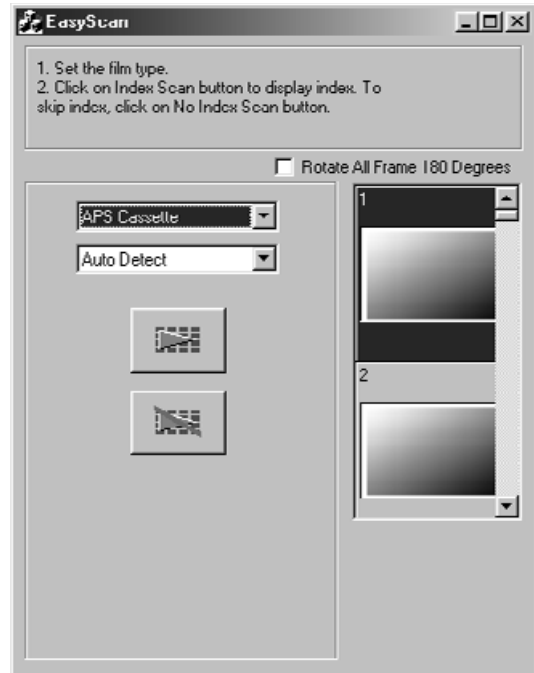

Setting the usage

1. Select the image usage setting from the radio button list displayed in the scan window.

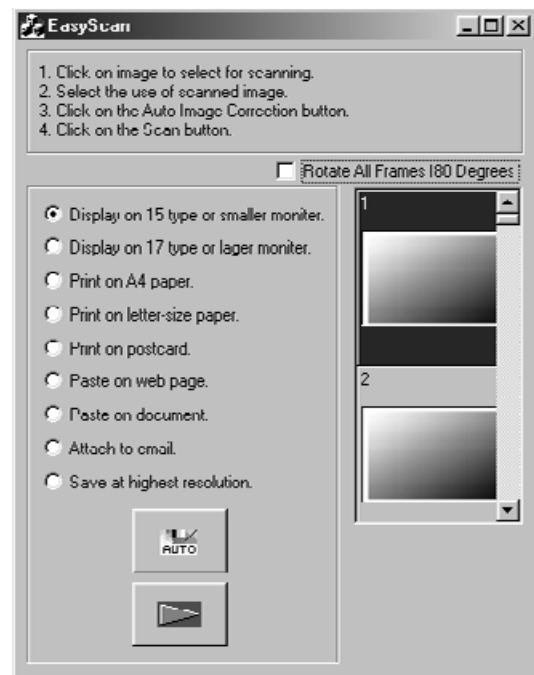

Image Correction

1. Perform the auto image correction using the 'Auto Image Correction' button if necessary.

- The image correction matching to the image will be applied automatically.

Rotate

1. Rotate the image 180° if necessary.

SPECIFY THE JOB TYPE/SAVING

1. Click on the Scan button to scan.

- When the 'file saving dialog box' appears, select the file format and save the scan.

File format: BMP JPEG, TIFF (Windows)
 PICT, JPEG, TIFF (Macintosh)

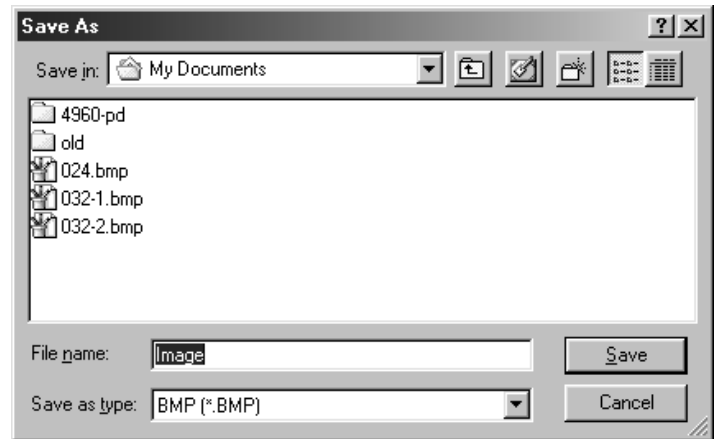

INDEX SCAN

SCANNING FLOW

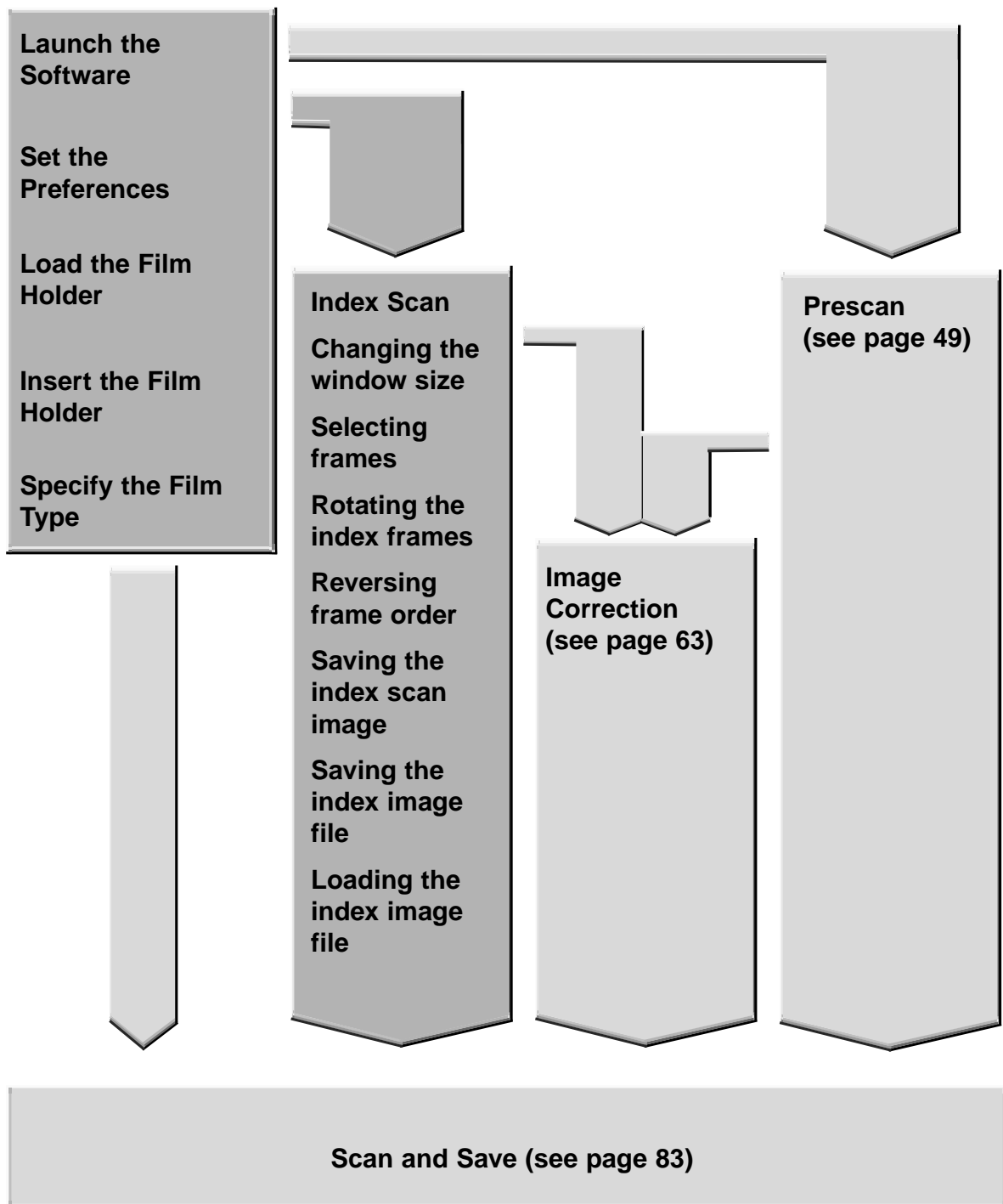

LAUNCHING THE SOFTWARE

The TWAIN driver allows you to control the software through another application, such as your image editing software.

Launching the TWAIN Driver – Windows

This manual uses Adobe Photoshop LE as the host application. Commands may vary among applications.

1. Open the host application.
2. Select File > Import > Select TWAIN_32 Source...

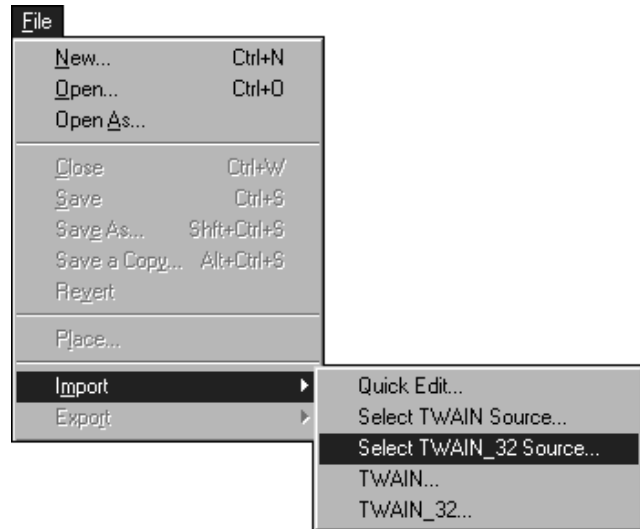

The Select Source dialog box appears.

3. Select DS_Dual2 1.0, then click on Select.

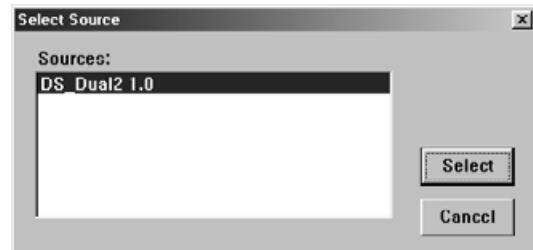

4. Select File > Import > TWAIN_32.

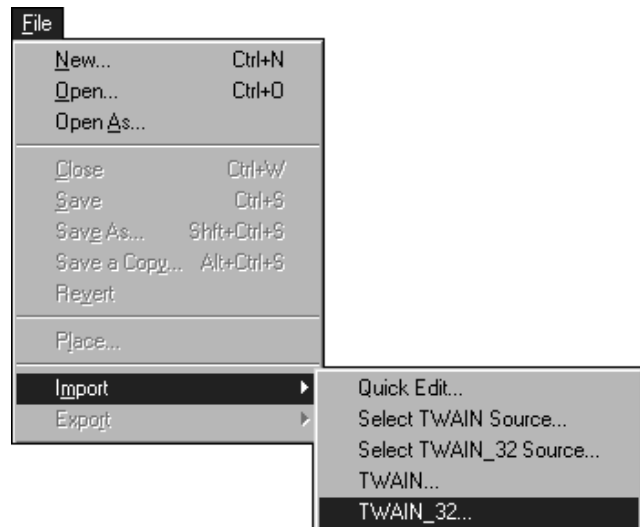

The software is ready for use when the Main window appears (page 38).

The plug-in software lets you access the software through Adobe Photoshop.

Launching the Plug-in – Macintosh

1. Launch Adobe Photoshop.
2. Photoshop LE, 4.0.1 and newer:
 Select File > Import > DS_Dual2 Plug-in.
 Photoshop 3.0.5:
 Select File > Acquire > DS_Dual2 Plug-in

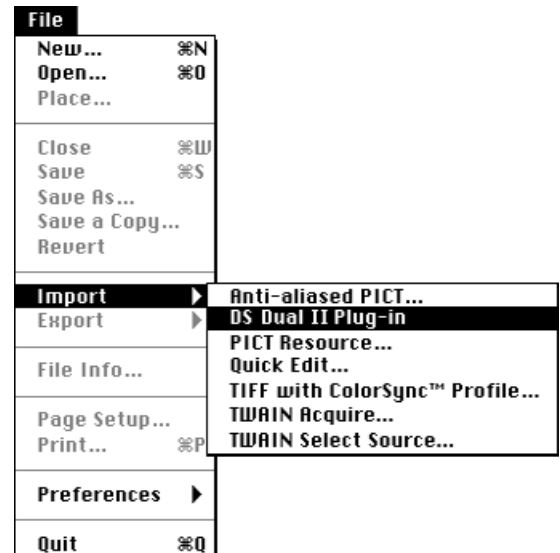

The software is ready for use when the Main window appears (page 38).

Use the utility software, as a stand alone application, when you just want to scan the photographic image and store.

Launching the Utility Software

Windows

Select Start > Programs > Minolta Dimâge Scan Dual2 ver.1.0 > DS Dual II Utility

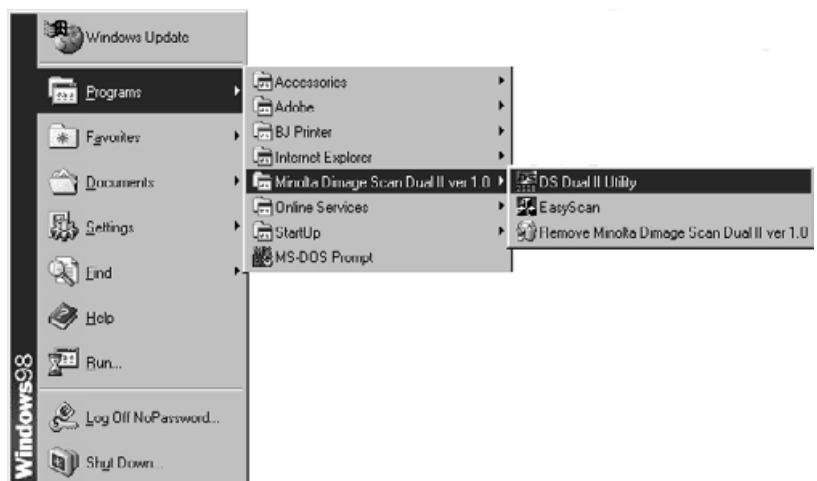

Macintosh

Double click on .

The software is ready for use when the Main window appears (page 38).

MAIN WINDOW – NAME OF PARTS

MAIN window

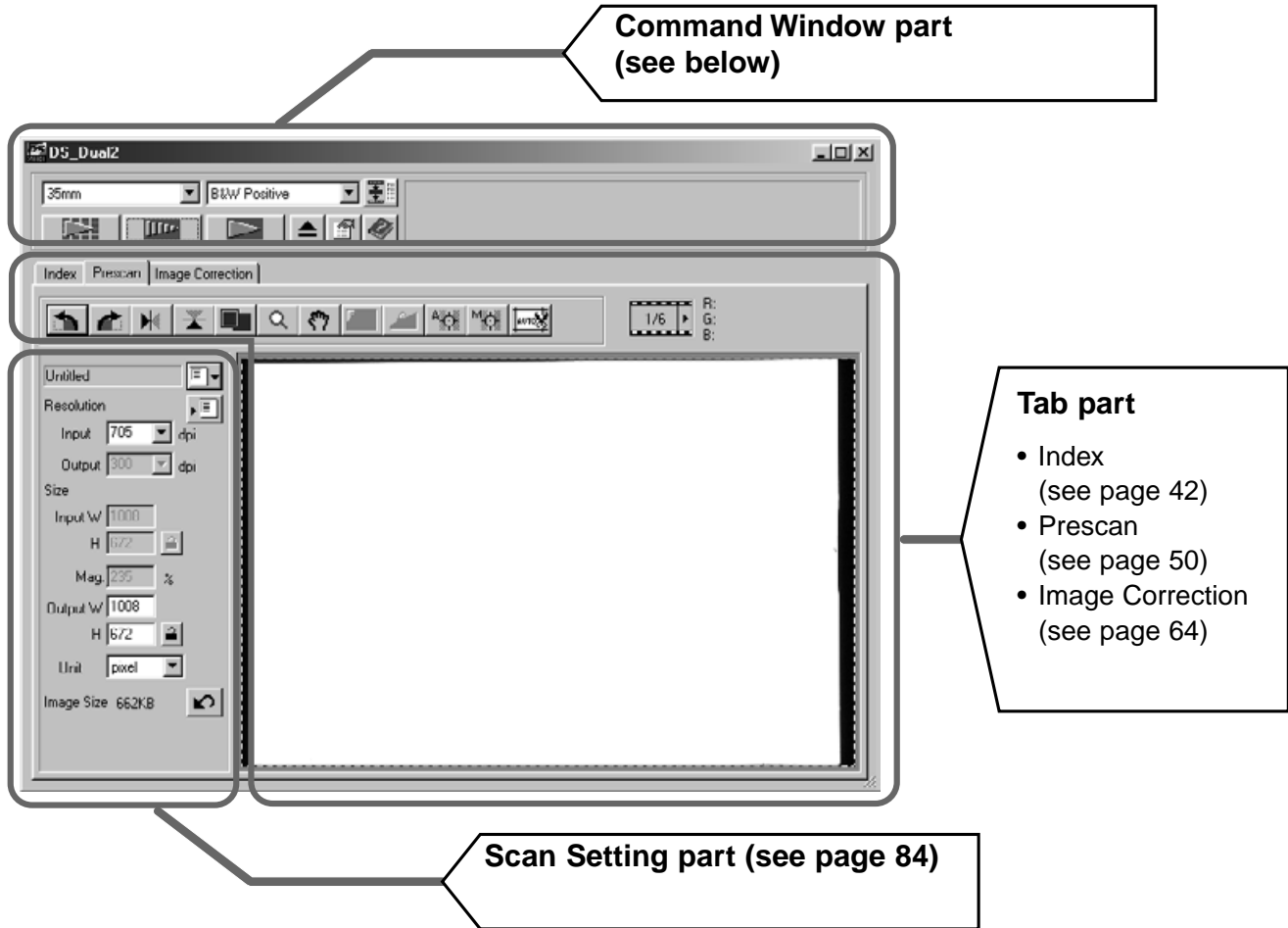

The Command window part – Name of parts

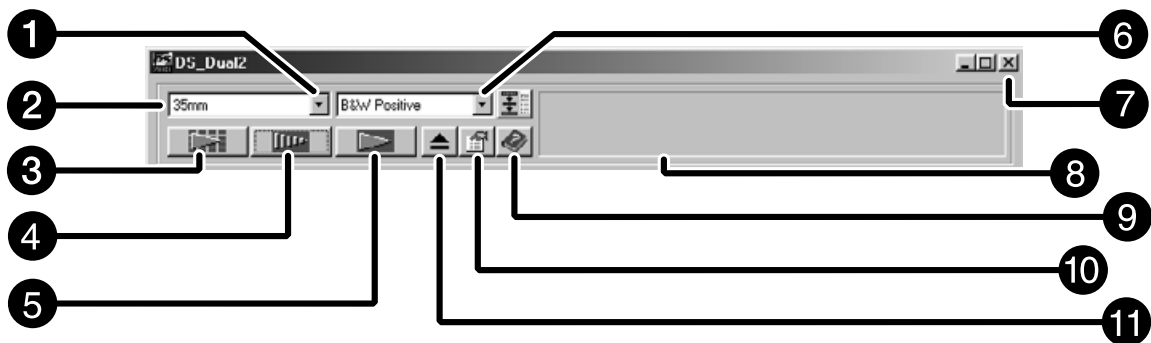

- | | |
|------------------------|---------------------------------|
| ① Film Type list box | ⑦ Close button |
| ② Film format list box | ⑧ Status bar |
| ③ Index Scan button | ⑨ Help button (? on Macintosh) |
| ④ Prescan button | ⑩ Preferences button |
| ⑤ Scan button | ⑪ Eject button |
| ⑥ Navigation button | |

SETTING THE PREFERENCES

1. Click on  in the Command window.

The Preference Dialog Box – Name of parts



2. Set the preferences as desired.

- 1 Auto Expose for Slides checkbox

Select this checkbox when scanning underexposed slides.

- 2 Scan AF checkbox

Select this checkbox to use the auto focus function when performing the index scan, preview scan and AF scan.

- 3 Close Driver After Scanning checkbox

Closes the scanner's driver software after the scan is complete.

- 4 Color depth setting box

The pixel depth of each color channel used to scan your image (RGB or CMY).

Three options are available:

- 8-bit – over 16.7 million colors
- 16-bit – over 2.8 billion colors
- 16-bit linear – same as 16 bit, but image correction is not applied when the image is scanned.

Continued on the following page.

5 Index Scan priority

- Speed – Creates a thumbnail representation of each frame on the roll.
- Quality – Thumbnail and Prescan images are created for each frame on the roll.
 - Double-clicking on the index image opens the ready-made prescan image.

3. When scanning APS, set the Preferences as desired in the APS settings part.

- De-select the Close Driver After Scanning checkbox when scanning multiple images at the same time.

6 Auto film rewind

Clicking on the Rewind button in the Command window automatically rewinds the film into the APS cassette before the APS adapter is ejected.

7 Rotate All Frames 180 Degrees

Rotates all frames in the Index window 180°.

4. Click on to accept the new preference settings.

- Changes to the Preference settings take effect immediately.

SETTING THE FILM TYPE

1. Insert the holder into the scanner.
2. Select 35mm or APS Cassette from the film format drop-down list in the Command window.

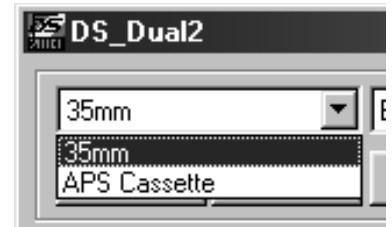

3. Select the film type from the film type drop-down list.

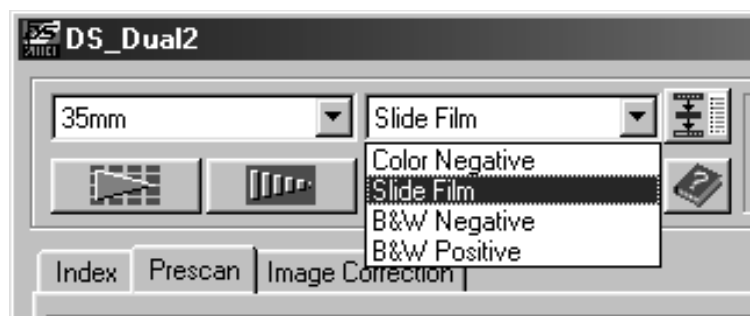

Select APS Cassette

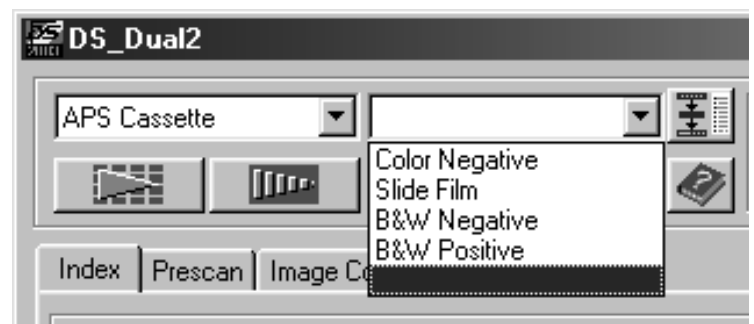

INDEX SCAN – NAME OF PARTS

Index scan displays a scan of each image on the film holder in the Index tab. The time required for an index scan depends on the performance of your computer.

If you don't want to index scan the entire roll, select the frame number of the image you want to scan from the index print provided by your photofinisher. Click on the appropriate image box in the index tab to select an image for prescanning or scanning.

- When APS is selected in the Command window, there are two options for making an index scan are available Speed or Quality. Select the desired option in the Preference dialog box (see page 39).

Click on Index tab in the Main window.

The Index tab part – Names of Parts

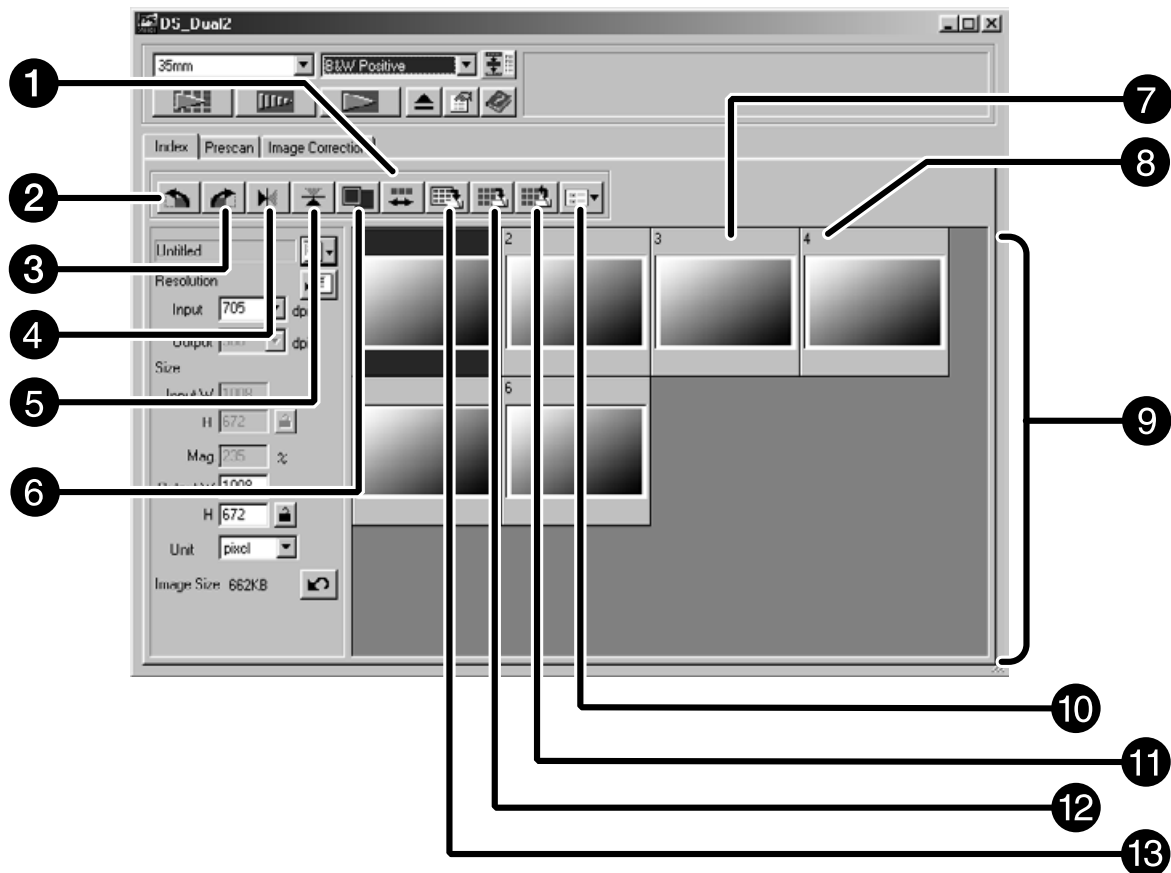

- 1 Reverse frame order button
- 2 Rotate left button
- 3 Rotate right button
- 4 Flip Horizontal button
- 5 Flip Vertical button
- 6 Full-Screen View button
- 7 Index Image frame

- 8 Frame number
- 9 Index Image area
- 10 Image Correction Job Load button
- 11 Save Index Image button
- 12 Index Load button
- 13 Save Index scan button

INDEX SCAN

Index scan

1. Click on  in the Command window.

- All frames on the film folder will be scanned and appear in the Index tab.

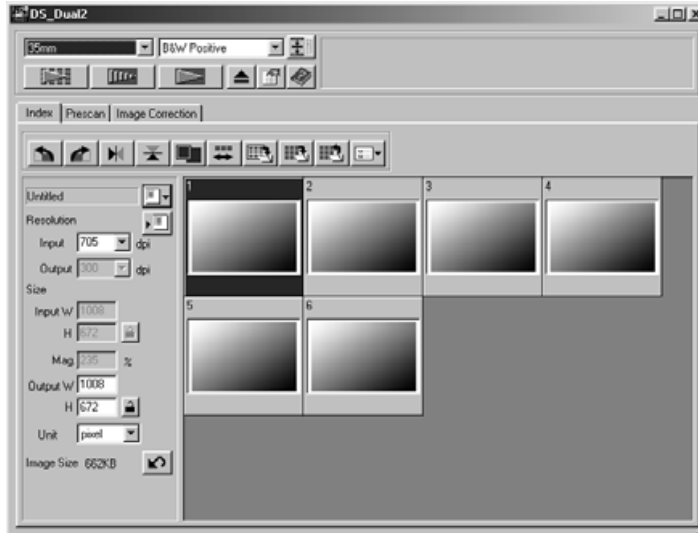

NOTE:

- To cancel the index scan, press the escape key (⌘-.) Command and period for the Macintosh) until the Cancelling Index Scan message box appears.
- The completed index scans will appear in the Index tab.
- Frames that have not been index scanned can still be selected for prescanning and scanning.

Changing the Window Size

Change the size of the Index tab window as desired. The position of the frames will change accordingly.

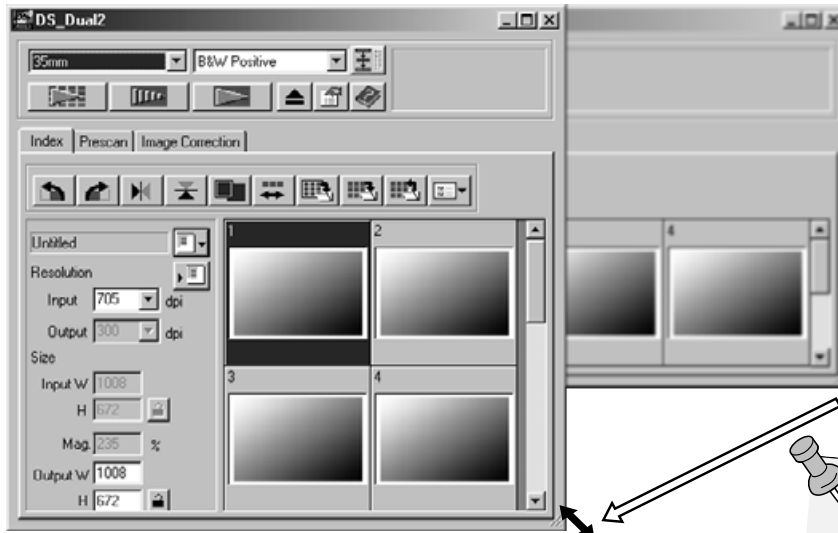

NOTE:

- When the Full-Screen View button is not clicked, the size and shape of the index frames does not change.
- When the Full-Screen View button is clicked, the size of the index frames changes automatically and all frames are displayed.

1. Click on the corner tab (lower-right corner) and drag to reach the desired size.

SCANNING THE IMAGE

Selecting Frames

1. Click on an image to select it for scanning.

- Selected images are surrounded by a dark gray frame.



- Press the control key (⌘ key for the Macintosh) while clicking to select additional frames for scanning.
- Press the control key (⌘ key for the Macintosh) while clicking to deselect an image.

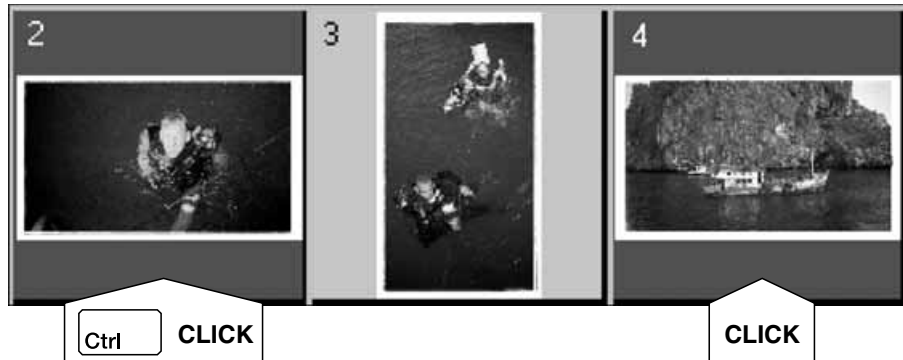

- Press the shift key while clicking to select all the frames between the current frame and the last frame selected.

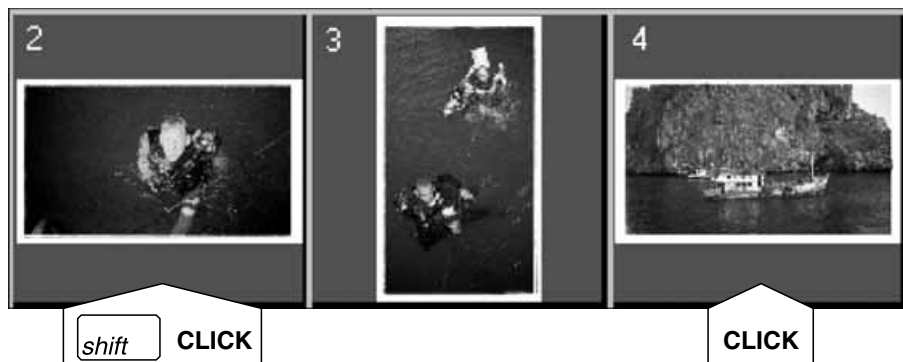

2. Click on to scan the selected image (s).

- The scan is cancelled if more than the number of frames selected is greater than the Max # of Frames set in the Preferences dialog box. See page 39.
- The image will be opened in your photo application software when the scanner's driver software is closed.
- Some photo applications can only acquire one image at a time.

3. Refer to page 46 to save the scanned image(s).

- Multiple scans will be saved using the selected file name and numbered chronologically. Example: File_Name01, File_Name02, File_Name03...

NOTE:





Click on  to save the index as an image file.

- The image can be saved in JPEG or BMP format (JPEG or PICT format for the Macintosh).

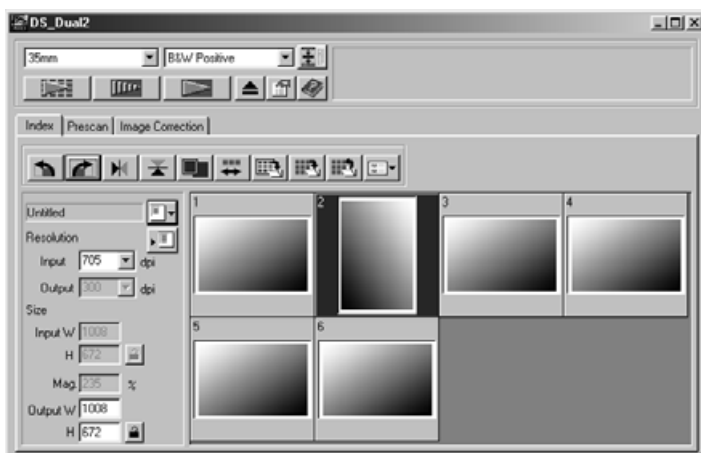
Rotating the Index Frames

Rotate index frames so they appear in the Index scan tab window with the proper orientation.



1. Select the desired frames, then click on ,  or , .
 - The selected frames will rotate in 90° increments either clockwise or counter-clockwise or flip vertically or horizontally.
 - Rotating the index frame will not affect the Prescan or Scan.

Reversing Frame order

Some cameras are reverse-winding, so the last frame is exposed at the beginning of the roll. The order of the Index tab can be reversed to correct the chronology.

1. Click on .

SAVING INDEX SCAN IMAGE

When performing the index scan, all the thumbnail images displayed in the index window can be saved as an image file.

1. Click on the 'Save Index Image' button in the Main window.

- The standard file save dialog box for each operating system will appear.

[Windows®]

- For Windows®, the file can be saved in the Windows® Bitmap (BMP) or JPEG format.

[Macintosh]

- For Macintosh, the file can be saved in the PICT or JPEG format.

2. Enter the desired file name, select the file destination and then click on Save.

- All the thumbnail images in the index window will be saved in the selected location with the specified file name.
- For Windows®, the file can be saved in the Windows® Bitmap (BMP) or JPEG format. For Macintosh, the file can be saved in the PICT or JPEG format.

SAVING INDEX IMAGE FILE

Some index images displayed in the index tab can be saved as an index file.

1. Click on the 'Save Index' button in the Main window.

- The standard file save dialog box for each operating system will appear.

[Windows®]

- For Windows®, the file can be saved in the Windows® Bitmap (BMP) or JPEG format.

[Macintosh]

- For Macintosh, the file can be saved in the PICT or JPEG format.

2. Enter the desired file name, select the file destination and then click on Save.

- When the index images are displayed, these images are saved regardless of the film set in the scanner.
- When the index images are not displayed, the index images are saved after performing the index scan.
- If there are index images which have not been scanned yet, those images will be scanned and then all index images including those images will be saved.

LOADING INDEX IMAGE FILE

The index file can be displayed in the index tab after reading the saved index file. The previously displayed preview images are erased.

1. Click on the 'Read Saved Index' button in the Main window.

- The standard file open dialog box for each operating system will appear.

[Windows®]

- For Windows®, the file can be saved in the Windows® Bitmap (BMP) or JPEG format.

[Macintosh]

- For Macintosh, the file can be saved in the PICT or JPEG format.

2. Select the index file to be read and then click on OK.

PREVIEW SCAN

SCANNING FLOW

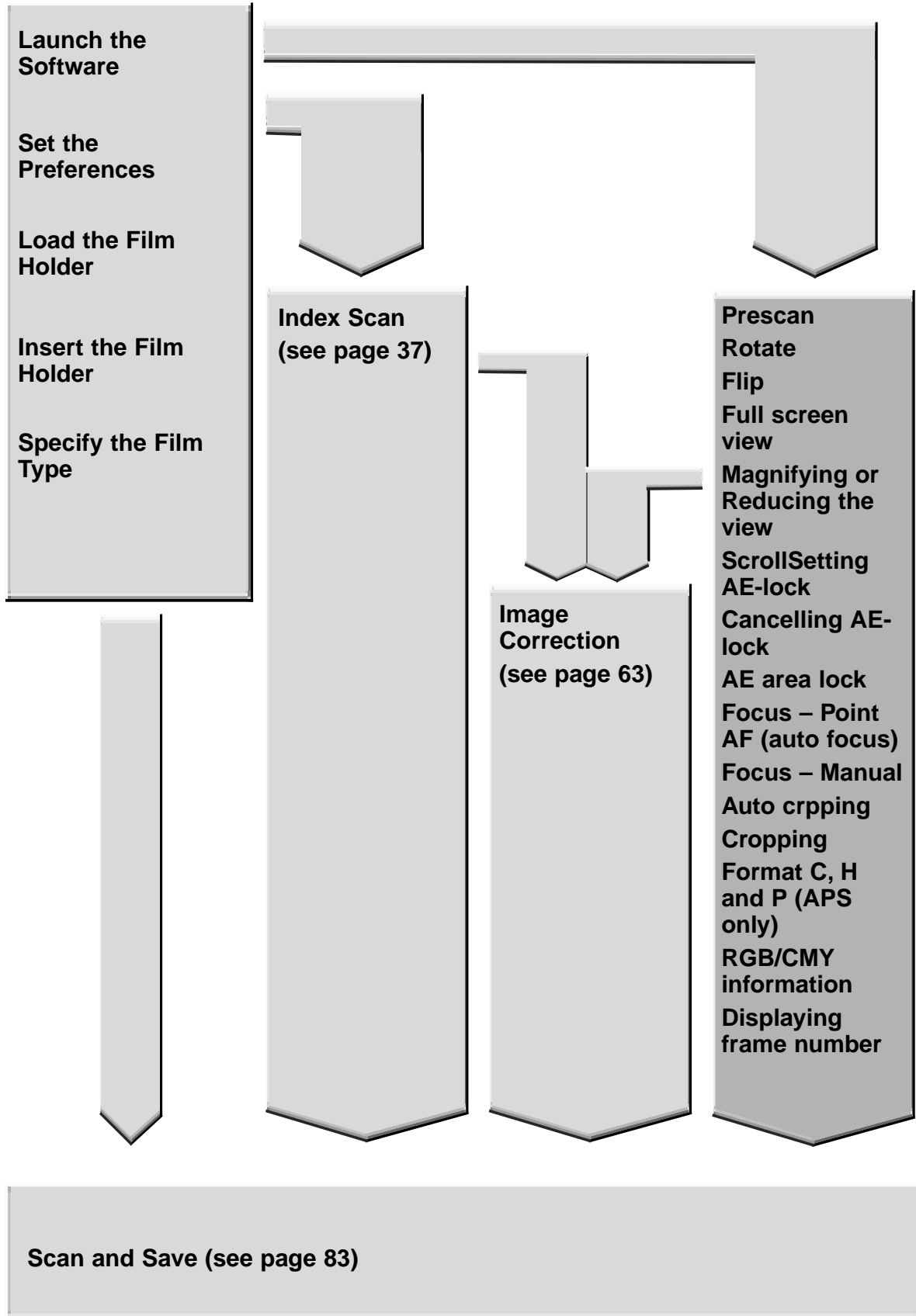

PRESCAN

Prescanning creates a scan of the image that you can apply and view color, contrast, orientation, and brightness corrections before clicking on the Scan button. This ensures that final scan will be the best it can be.

Click on the Prescan tab in the Main window.

The Prescan tab part – Names of parts

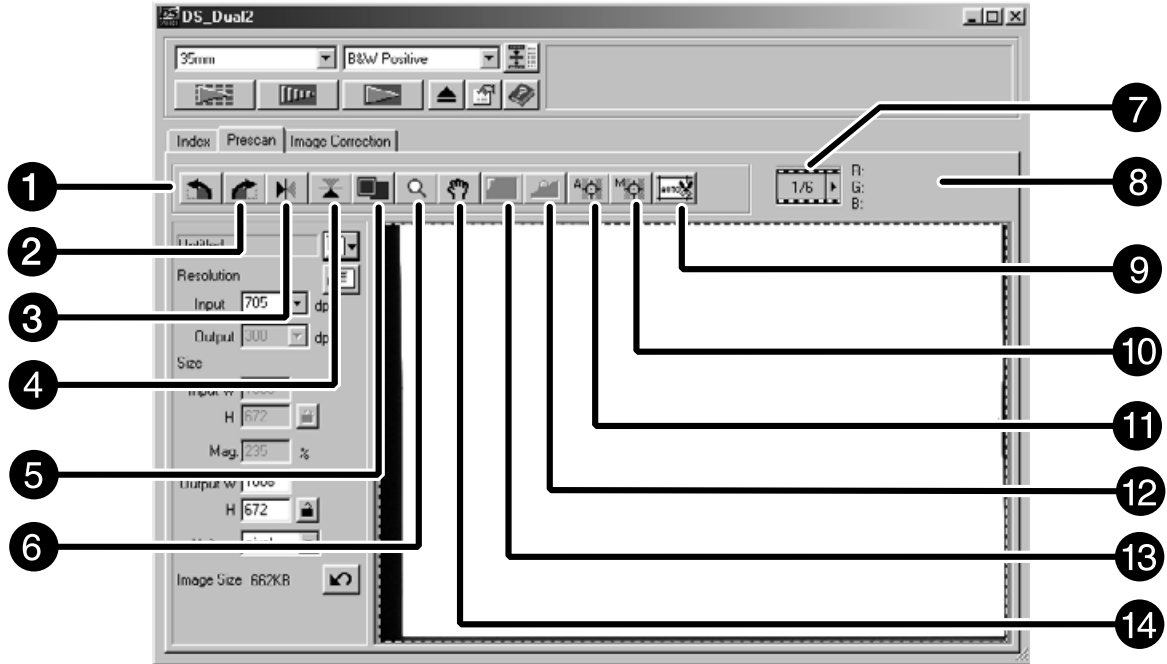

- | | |
|---------------------------|--|
| 1 Rotate Left button | 8 RGB/CMY display |
| 2 Rotate Right button | 9 Auto Holder/Mount Crop Adjustment button |
| 3 Flip Horizontal button | 10 Manual Focus button |
| 4 Flip Vertical button | 11 Point AF button |
| 5 Full-Screen View button | 12 AE Lock button |
| 6 Zoom button | 13 AE Area Lock button |
| 7 Frame number indicator | 14 Grab button |

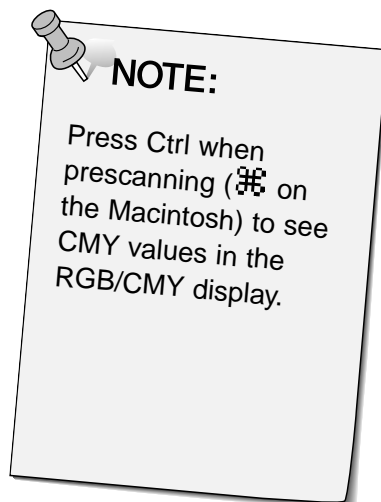
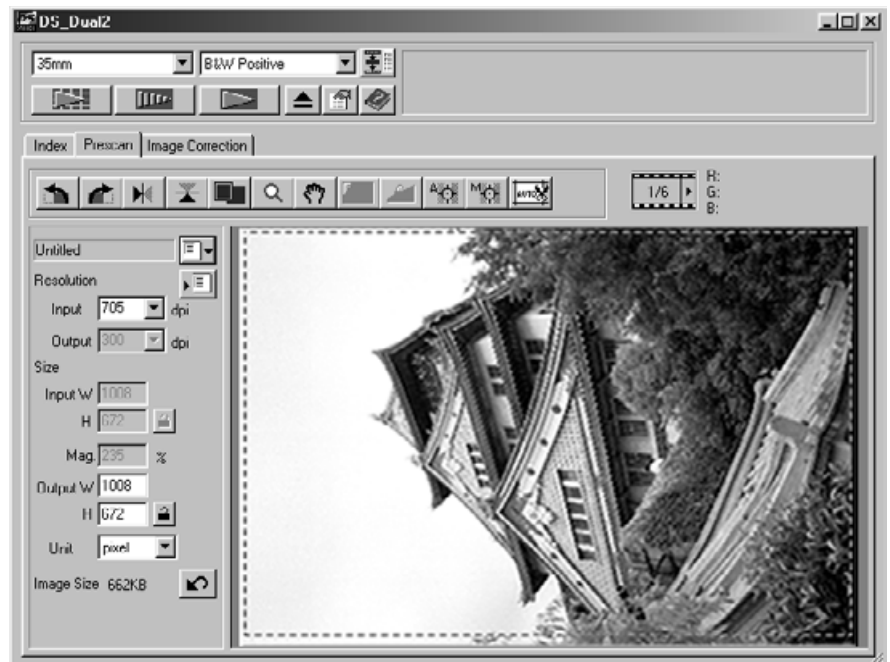

1. Click on  in the Command window.

The prescanned image will appear in the Prescan tab.



ORIENTING THE IMAGE

Rotate

Click on the  and  buttons to correct the orientation of your image before scanning. Changes will be reflected in the prescan image.



Click on  to rotate the image 90° clockwise.



Click on  to rotate the image 90° counter-clockwise.



Flip

The  and  buttons let you flip the image left to right or top to bottom before scanning. Changes will be reflected in the prescan image.

Click on  to flip the image top to bottom.



- The image is upside down compared to the original prescan.

Click on  to flip the image left-to-right.



- Image is reversed compared to the original scan.

Full screen view



This function allows you to display the entire prescanned image in the Prescan tab.

1. Click on .

Magnifying or Reducing the View

Use the zoom button  to increase or reduce the image magnification.

Zooming In

1. Click on .
 - The pointer will change to .
2. Click anywhere on the image to zoom in.
 - The clicked position will be the center of the magnified view in the Prescan tab.
 - The “+” disappears from the magnifier icon when the maximum image magnification has been reached.



Zooming Out

1. Press and hold the Ctrl key (option key on the Macintosh) to reduce the image magnification.
 - The pointer will change to .
2. Click anywhere on the image to zoom out.
 - The “-“ disappears from the magnifier icon when the minimum image magnification has been reached.



Scroll

Use the grab button to scroll an enlarged image.

-  can only be selected when the image has been magnified beyond the limits of the Prescan tab.

1. Click on  in the Prescan image display area.

- The pointer will change to .

2. Click on and drag the image to the desired location.

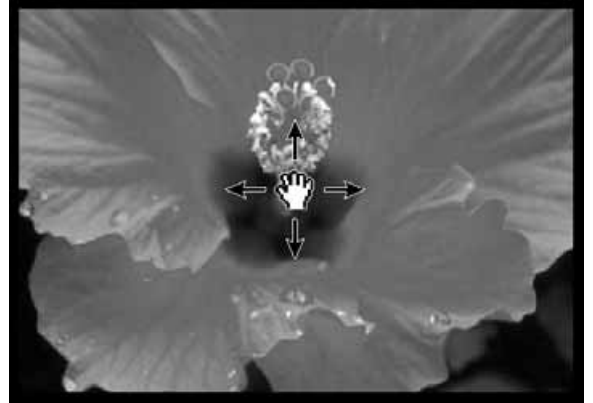

AUTO-EXPOSURE LOCK

Especially useful when scanning bracketed exposures, AE (auto exposure) lock lets you scan multiple images with the same initial exposure settings. AE Lock saves the automatic exposure settings determined when an image is prescanned. Subsequent images are prescanned using the 'locked' exposure settings.

- AE-lock does not save exposure corrections made in the Variations, or Tone Curves and Histogram dialog box.

Setting AE-Lock

After prescanning the image...

1. Click on  .

-  can not be selected until an image has been prescanned.

2. Select another image, then click on  .

- The scanner skips the setting exposure step in the prescan sequence.

Images will be scanned using the AE lock settings until AE lock is cancelled or the scanner is reinitialized.

Cancelling AE-Lock

1. Click on  .

2. Click on  to prescan the image again.

AE AREA LOCK

The AE area in auto exposure adjusting mode can be changed and the exposure of that area is adjusted automatically.

Perform the procedure below after prescanning the image.

1. Click on  .
2. **Press the Shift key.**
 - The AE area is indicated by a line instead of the cropping area indicated by a dashed line.
3. **While pressing down the Shift key, change the AE area.**
 - The operation is the same as that of changing the cropping area except that the shift key should be used.
 - For details, see “Cropping” (see page 60).

Focus

The Dimâge Scan Dual2 uses the CCD sensor for autofocus. Autofocus uses the center of the image to determine focus. Normally, this results in an excellent scan because the film plane is flat. However, if the film is warped or curled, or if Autofocus is turned off in the preferences, focus may not be accurate. In this case, the focus adjustment should be performed again using the Point AF or Manual Focus function.

- Automatic autofocus can be turned on and off in the Preferences (page 39).

POINT AF

This allows you to use autofocus on a specific area of the image.

1. **Click on .**
 - The pointer will change to the Point AF icon.
 - Click on the Point AF button again to escape the function.
2. **Click on the area of the image to be in the sharp focus.**
 - Autofocus will begin, then a new prescan will start.
 - The prescanned image will appear in the Prescan window when complete.

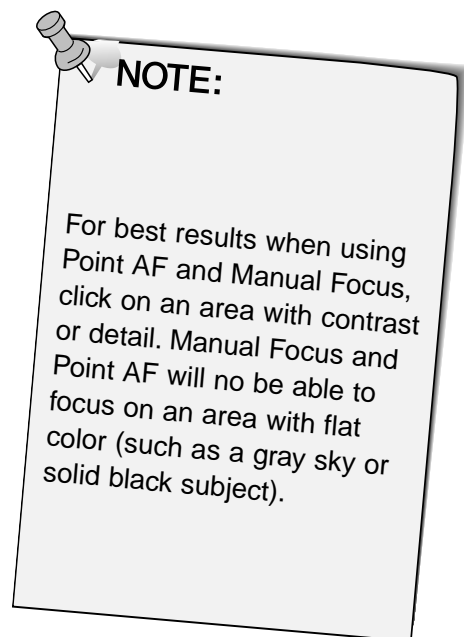

MANUAL FOCUS

Use manual focus on a specific area of the image or to reduce the appearance of grain in grainy film (such as high-speed or pushed film) by slightly defocusing it.

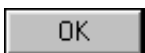
1. **Click on .**
 - The pointer will change to the Manual Focus icon.
 - Click on the Manual Focus button again to escape the function.
2. **Click on the area of the image to be in sharp focus.**
 - The Focus Control Window dialog box will appear.
3. **Adjust the slider until the black and gray lines are at their longest for maximum focus.**
 - Click and drag the slider to the left and right. Click on the slider bar to make a larger change.
 - To slightly defocus, adjust the sliders until the black bar is a little shorter than the gray bar.
4. **Click on .**
 - A new prescan will begin.
 - The prescanned image will appear in the Prescan tab when complete.

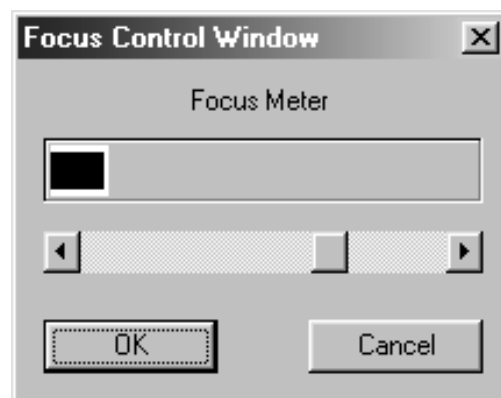

CROPPING THE IMAGE

Auto Cropping

The cropping area is determined automatically so that the holder or slide mount frame in the prescan image is removed.

Click on  .

Cropping

The cropping frame defines how much of the prescan image will be scanned. The dimensions of the cropping frame are displayed in the lower left corner of the Prescan tab.

To enlarge or reduce the size of the cropping frame...

Click on the cropping frame and drag the pointer in or out.

- Click on the corners and drag to resize the cropping frame proportionally.
- Click on the sides and drag to resize the cropping frame non-proportionally.

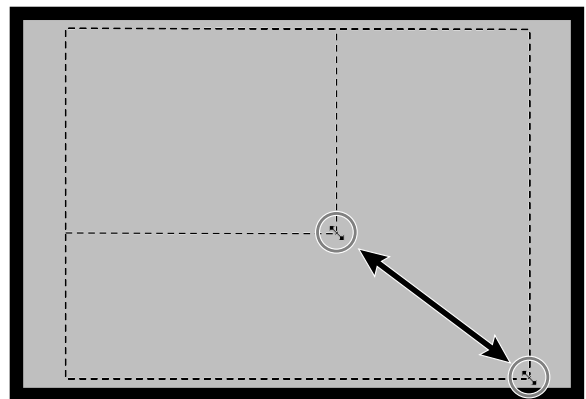

To move the cropping frame...

Click inside the cropping frame, then drag the cropping frame to its new location.

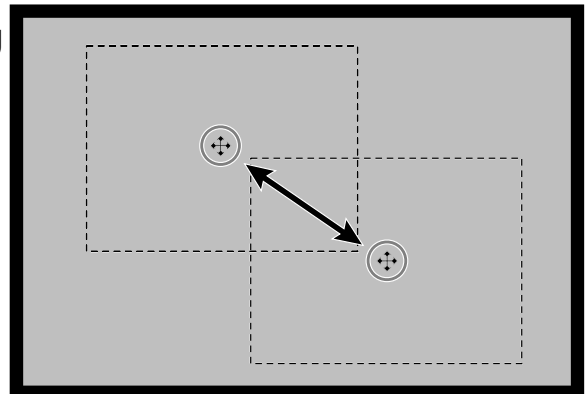

To define a new cropping frame...

Click and drag outside the current cropping frame.

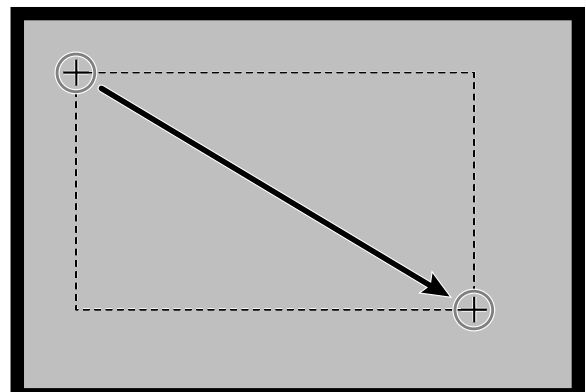

PRESCAN AND IMAGE CORRECTION

1. Click on an image or an image box, then click on . The image will be prescanned, then opened in the Prescan tab.

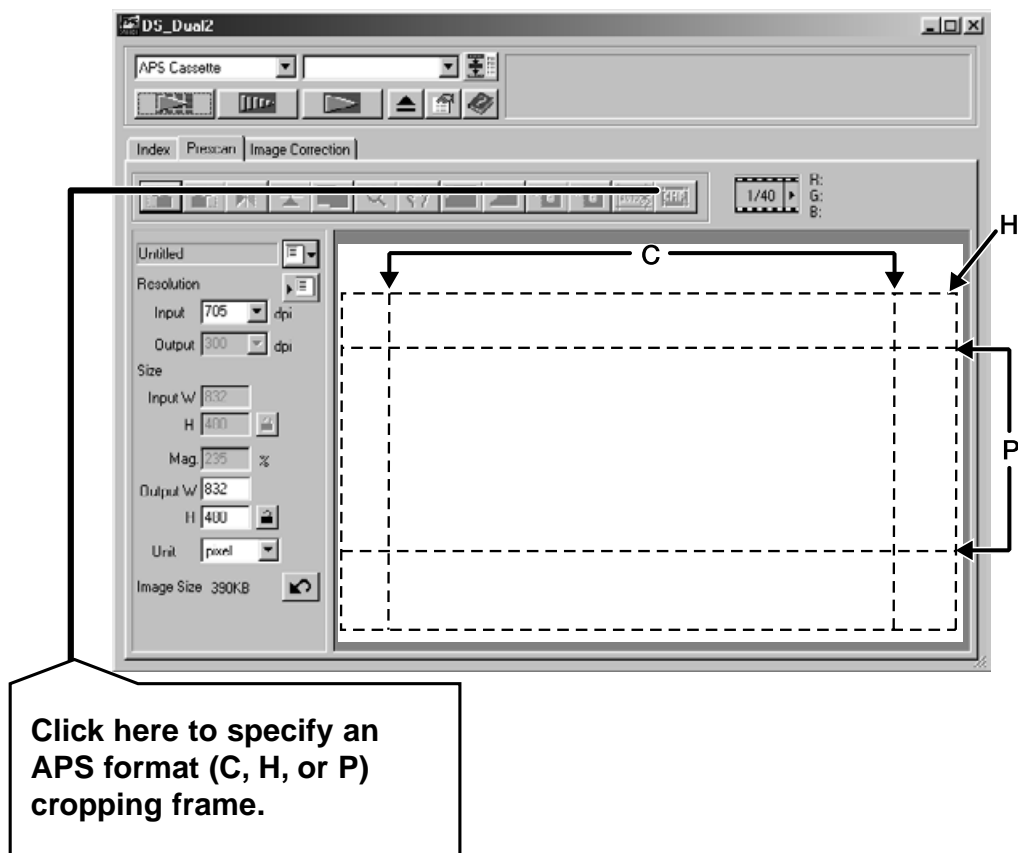

2. Orient and crop the image as desired (see page 52 to 57, 60).
3. Apply contrast, brightness, and color corrections (see page 65 to 77).
4. Select the desired job type (see page 84 to 88).
 - Only one job type can be selected when multiple images are scanned at the same time.
5. Close the Prescan tab window to return to the Index tab window.
 - Adjustments made in the Prescan tab are held until the image is scanned or the driver software is closed.

APS formats; C, H and P (APS only)

When APS is selected in the Main Window, the CHP button allows you to quickly and easily define the cropping frame by the standard APS format; C, H and P.

1. Click on  to display the APS cropping frames.

- The cropping frames are displayed in sequence with each click of the CHP button.

RGB/CMY information

The RGB information from the pointer position is always displayed in the Prescan tab. The information is described in brightness levels from 0 to 255. However, the display can be changed to show CMY information.

1. Press and hold the Shift key (command key on the Macintosh) with the Prescan tab open. The RGB information will change to CMY.

Displaying Frame number

This function allows you to display the current frame number and total frame number.

- 1. To display the next frame, click on ► .**
- 2. To display the previous frame, click on ◀ .**

IMAGE CORRECTION

IMAGE CORRECTION FLOW

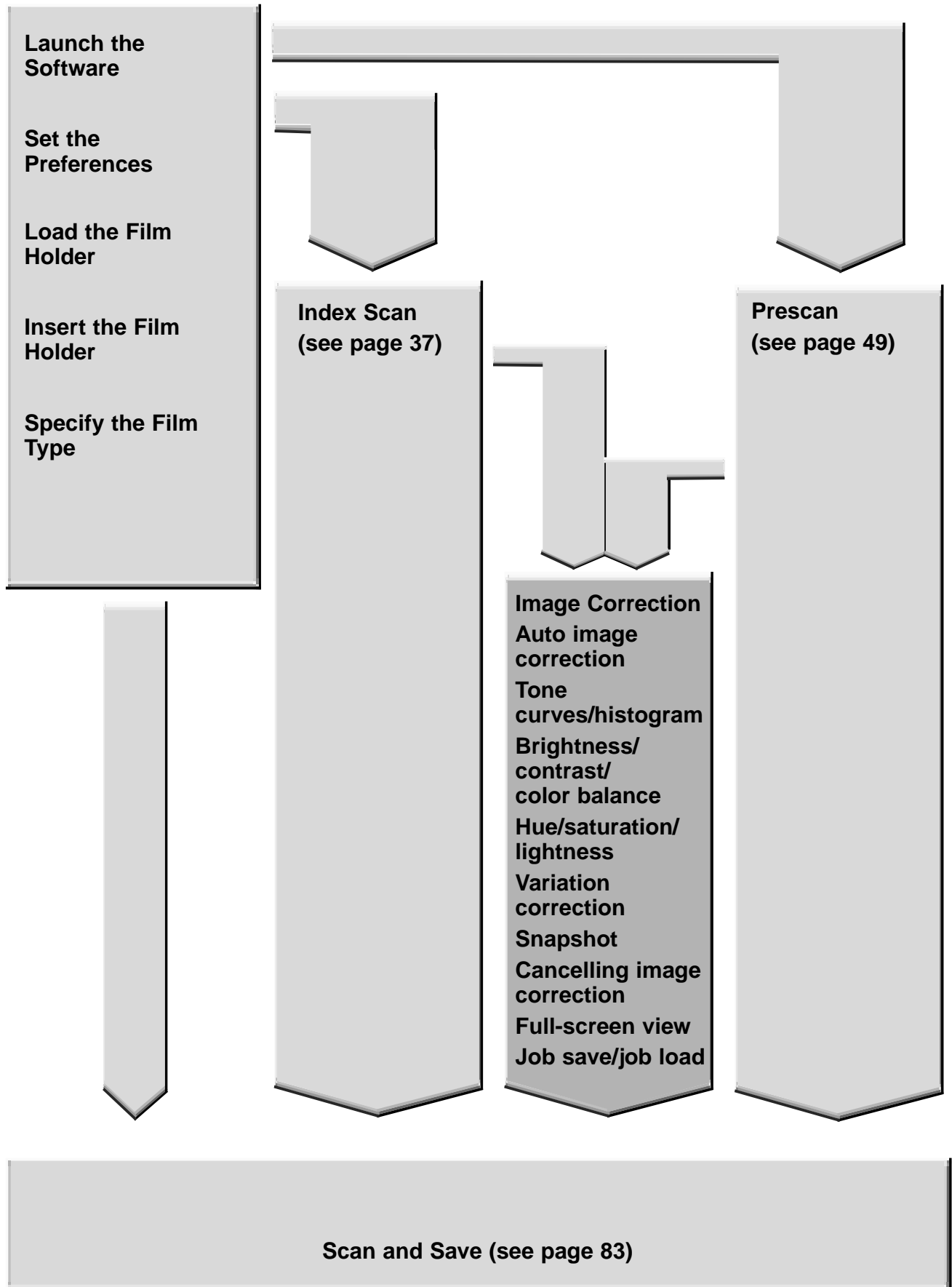
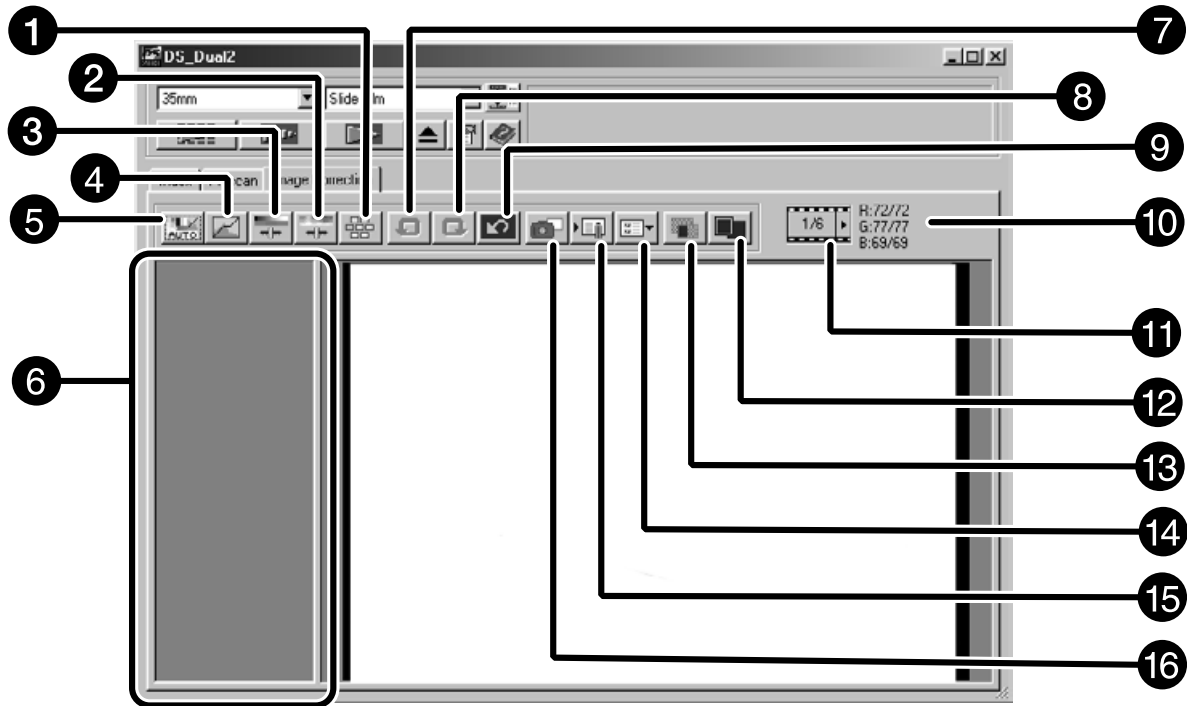

IMAGE CORRECTION

This scanner gives you three options for correcting the brightness, contrast, and color balance of the final scan.

Click on the Image Correction tab in the Main window.

The Image Correction tab part – Names of parts



- | | |
|---|--|
| 1 Variations button | 9 Correction Reset button |
| 2 Hue/Saturation/Lightness Correction button | 10 Frame Number indicator |
| 3 Brightness/Contrast/Color Balance Correction button | 11 RGB value display |
| 4 Tone Curves/Histogram Correction button | 12 Full-Screen View button |
| 5 Auto Image Correction button | 13 Pre/Post Correction Comparison Display button |
| 6 Snapshot display area | 14 Image Correction Job Load button |
| 7 Undo button | 15 Image Correction Job Save button |
| 8 Redo button | 16 Snapshot button |

AUTO IMAGE CORRECTION

This function automatically performs the ideal correction for each image. All the corrections performed before clicking on the Auto Image Correction button will be reset. This function is available only when the Color depth is set to “8 bit” in the Preference Dialog box on page 39.

1. **Click on .**
 - The Keyword Selection dialog box is displayed.
2. **Insert the check mark in the “Select exposure keyword.” item.**
 - To determine the scene to be corrected automatically, insert the check mark in the “Auto correction” and then click on the OK button.
3. **Select a scene.**
 - When selected “Color cast”, you can also select another scene.

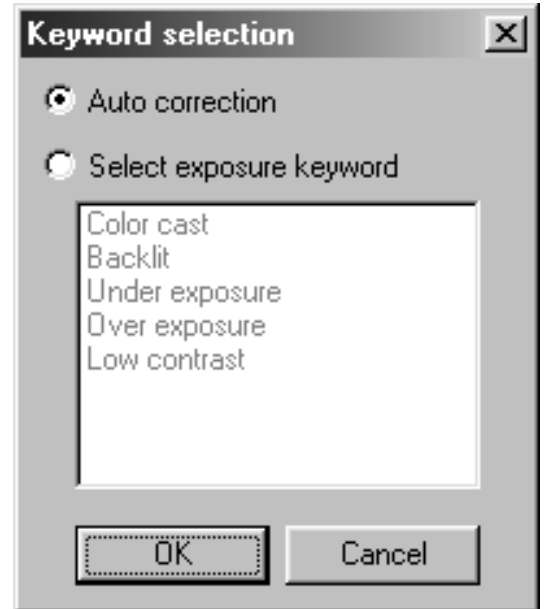

TONE CURVES/HISTOGRAM

When the Tone curves/Histogram Correction button is clicked, the Tone Curves and Histogram dialog box is displayed.

The Tone Curves part allows you to change the tone curves and directly correct the output value.

The Histogram part allows you to specify the input and output area from the information included in a film and correct images. Also, this dialog box displays the histogram of the image area inside the cropping frame in each RGB color. The level is indicated in 256 color steps (0 to 255) from left to right side.

The tone curves and histogram are linked to each other so that when the tone curve is corrected, the histogram is automatically corrected.

Click on  in the Image Correction tab.

The Tone Curves and Histogram Dialog Box – Names of Parts

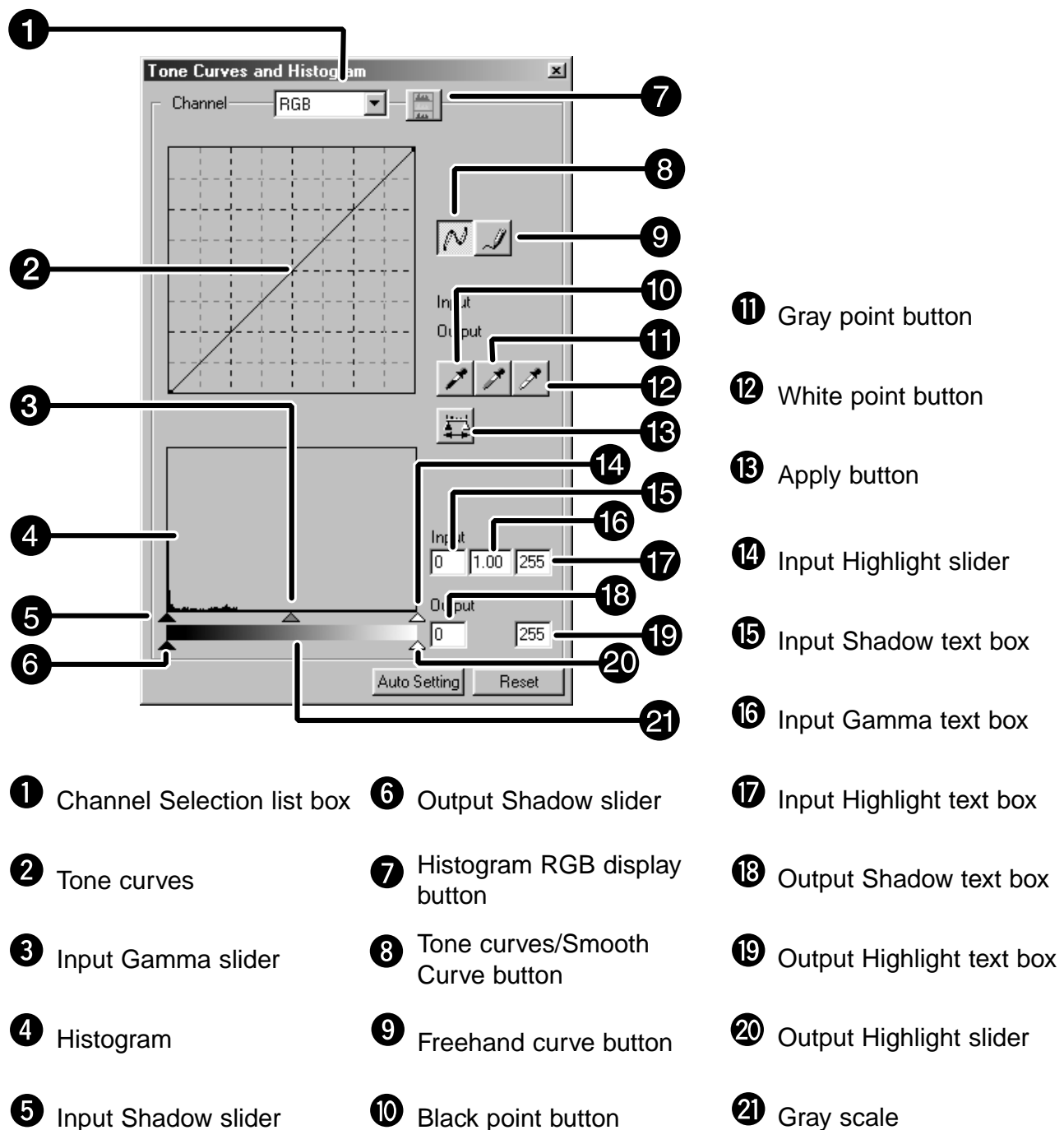

Correcting the Tone Curves

Changing the shape of a correction curve changes the output level for each corresponding input level. Changing the shape of the red, green, or blue curves affects color balance of the image. Changes to the RGB curve affect the image contrast and brightness.

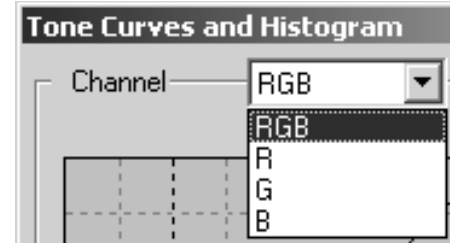

1. **Click on the arrow next to the channel selection list to display the available channel (R, G, B, RGB).**



2. **Select the channel of the color to be corrected.**
3. **Click and drag the portion of the curve to be changed.**
 - The coordinate value of the cursor is displayed from 0 to 255.
 - The corrected image by changing the tone curves is applied to the prescan image.
 - You can also change the tone curves by freehand.

Changing Tone Curves by Freehand

This function allows you to draw tone curves by freehand.

1. **Select the channel of the color (R, G, B, RGB) to be corrected from the channel selection menu.**
2. **Click on .**
 - The cursor changes to the pencil shape.
3. **Draw the desired curve by dragging.**
 - To smooth out the curve points, click on .
 - The change will be reflected in the prescan image.

Correcting the Histogram

The input slide bar has the Input shadow slider, Input gamma slider and Input Highlight slider. The output slide bar has the Output Highlight slider and Output shadow slider.

The image can be corrected by dragging the slider or inputting the value in the text box.

The change will reflect the prescan image.

1. Drag the slider to move it to the desired level or input the value in the text box.

- The change will be reflected in the prescan image.

Input Level Histogram

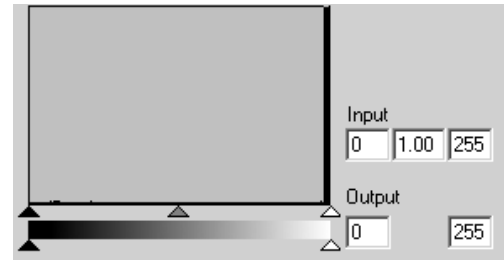

Displaying the Histogram of Each R, G, B color

1. Click on .

- When  is clicked again, the histogram of each R, G, B channel disappears.

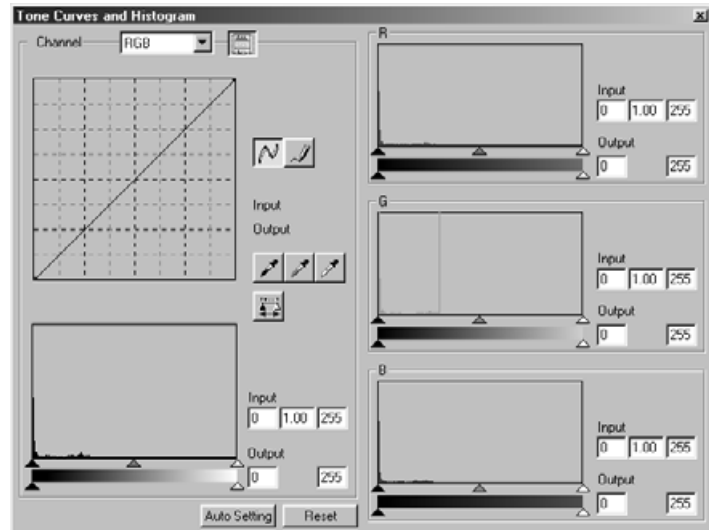



Setting the White or Black points

This function allows you to correct the highlight or shadow point to the specified value.

- Changes are automatically applied to the prescan image.

Setting the White Point

1. **Double-click on .**
 - The Point Value Setting dialog box is displayed.
2. **Input the desired white point value.**
3. **Click on .**
 - The cursor changes to the white dropper shape.
4. **Click the desired highlight point of the image.**
 - The image is corrected so that the point you clicked is highlight point. The color of the highlight point is the white dropper value you input in step 2.
 - The change will be reflected in the prescan image.

Point Value Setting dialog box

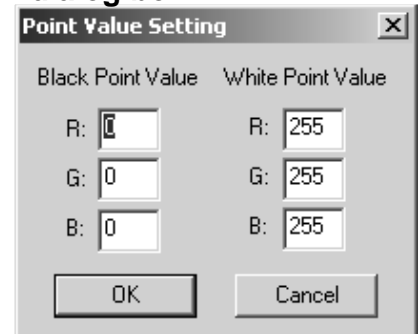

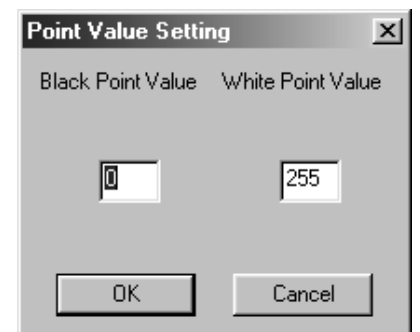

- When the film type is set to the color mode.



- When the film type is set to the monochrome mode.

Setting the Black point

1. **Double-click on .**
 - The Point Value Setting dialog box is displayed.
2. **Input the desired black point value.**
3. **Click on .**
 - The cursor changes to the black dropper shape.
4. **Click the desired shadow point of the image.**
 - The image is corrected so that the point you clicked is shadow point. The color of the shadow point is the black point value you input in step 2.
 - The change will be reflected in the prescan image.



Setting the Gray point

This function can specify the point to be changed to gray in the image.

1. Click on .
 - The cursor changes to the gray dropper shape.
2. Click the point to be changed to gray in the image.
 - The image is corrected so that the point you clicked is gray point.
 - The change will be reflected in the prescan image.



Viewing the Histogram of Images After Making Corrections

When  is clicked, the histogram of images after making corrections can be displayed.

The histogram after making corrections is displayed as long as you press this button. When the button is released, the histogram returns to the previous one.

Auto Setting

When the Auto Setting button is clicked, the image is corrected automatically by removing no information parts from the histogram and using all tone steps from 0 to 255.

Reset

If you click the Reset button, the settings in the current correction window are reset.

BRIGHTNESS/CONTRAST/COLOR BALANCE

When the Brightness/Contrast/Color Balance Correction button is clicked, the Brightness, Contrast and Color Balance Correction dialog box is displayed. The images can be corrected by dragging the slider or inputting the desired value in the text box.

Click on  in the Image Correction tab.

The Brightness, Contrast and Color Balance Correction Dialog box – Names of parts

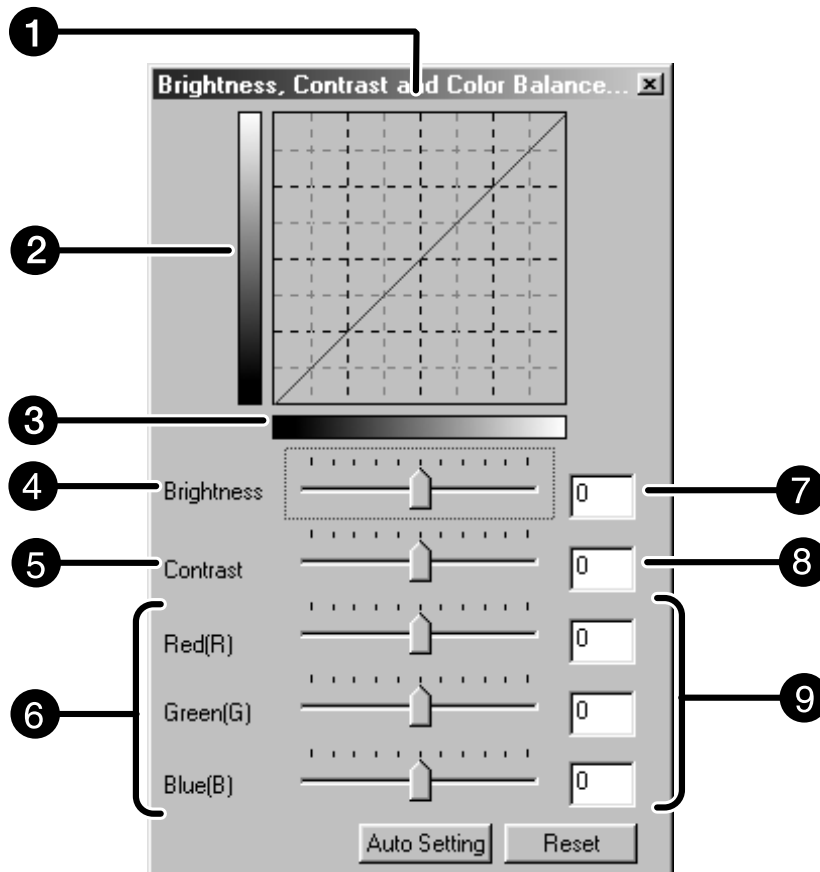

- | | |
|---------------------------------------|--------------------------|
| 1 Post-Correction LUT (Look Up Table) | 6 Color Balance slider |
| 2 Post-Correction Gray scale | 7 Brightness text box |
| 3 Pre-Correction Gray scale | 8 Contrast text box |
| 4 Brightness slider | 9 Color Balance text box |
| 5 Contrast slider | |

1. Drag the each Brightness, Contrast or Color balance slider, or input the desired value in the text box.

- The change will be reflected in the prescan image.
- Moving the Brightness, Contrast or Color balance slider changes “Post-Correction Gray Scale” and “Post-Correction LUT”.

Post-Correction LUT

The color of the image is changed as shown in the Post-Correction LUT.

The correspondence between the color displayed on the Pre-Correction Gray Scale and Post-Correction Gray Scale appears on the Post-Correction LUT.

Auto Setting

When the Auto Setting button is clicked, the brightness and contrast of the image is corrected automatically according to the lightness without changing the color balance.

Reset

If you click the Reset button, the settings in the current correction window are reset.

HUE/SATURATION/LIGHTNESS

When the Hue/Saturation/Lightness Correction button is clicked, the Hue, Saturation, Lightness Correction dialog box is displayed.

The images can be corrected by dragging the slider or inputting the desired value in the text box.

Click on  in the Image Correction tab.

The Hue, Saturation, Lightness Correction Dialog box – Names of parts

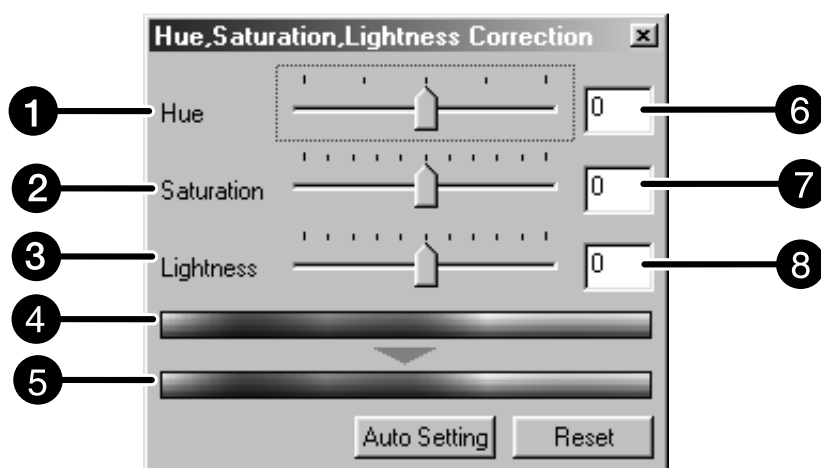

- | | |
|-------------------------------|--------------------------------|
| ① Hue-level slider | ⑤ Post-Correction Color Sample |
| ② Saturation slider | ⑥ Hue-level text box |
| ③ Lightness slider | ⑦ Saturation text box |
| ④ Pre-Correction Color Sample | ⑧ Lightness text box |

1. Drag the each Hue, Saturation or Lightness slider, or input the desired value in the text box.

- The change will be reflected in the prescan image.
- To change the color, move the Hue, Saturation or Lightness slider (or input the desired value in the text box).
Moving the slider changes "Pre-Correction Color Sample" and "Post-Correction Color Sample".

Pre-Correction Color Sample and Post-Correction Color Sample

The color of the image is changed as shown in "Correction Color Sample".

The color displayed in "Pre-Correction Color Sample" is changed as shown in "Post-Correction Color Sample".

Auto Setting

When the Auto Setting button is clicked, the saturation of the image is corrected automatically without changing the hue and lightness.

Reset

If you click the Reset button, the settings in the current correction window are reset.

VARIATION CORRECTION

The few frames of variation images are displayed around the corrected prescan image. You can correct the image while comparing with the variation images.

Click on  in the Image Correction tab.

The Variation Dialog Box – Names of Parts

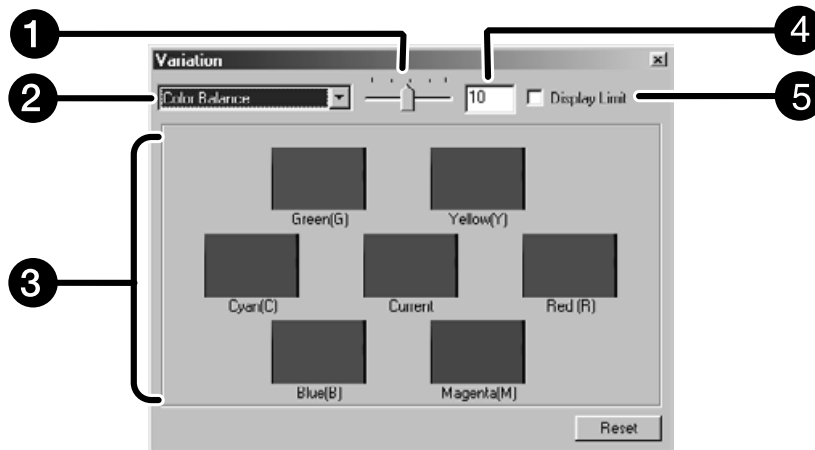

- ① Variation Amount Control slider
- ② Correction list box
- ③ Pre/Post Correction Image Display Area
- ④ Variation Amount Control text box
- ⑤ Limit Indication check box

Selecting the Correction Item

The correction item of the available variation can be selected from the color balance, brightness, contrast and saturation. However, the color balance and saturation are not available when using the monochrome film.

1. Click on the arrow next to the correction item in the correction list box. The available correction items are displayed.

2. Click the correction item.

The few frames of variation images corrected according to the selected correction item are displayed.

Color Balance Correction

The 6 images that have been corrected by one-step in each RGBCMY direction for the center current image are displayed.

1. **Click the color balance.**
 - The corrected 6 frames of variation images are displayed.
2. **Click the image in the direction you want to correct from the 6 frames of the variation images except for the center image.**
 - The image you clicked is placed in center and 6 new variation images that have been corrected by one-step in each direction.
3. **Correct the image properly by repeating the operation in step 2.**



Brightness & Contrast Correction

The 8 images of which brightness and contrast have been corrected by one-step in horizontal and vertical direction respectively for the center image are displayed. The variation images on the left and lower sides of the center image show the “-” correction effect, and on the right and upper sides of the center image show the “+” correction effect.

1. **Click the image in the direction you want to correct from the 8 frames of the variation images except the center image.**
 - The image you clicked is placed in the center and 8 new frames of the prescan images that have been corrected in each direction are displayed.

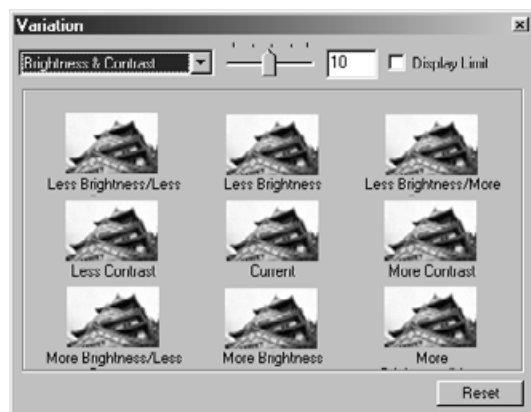

2. **Correct the image properly by repeating the operation in step 1.**

Saturation Correction

The 2 images of which saturation has been corrected on the right and left sides of the center image are displayed. The variation image on the left side shows reduced saturation, and on the right side shows increased saturation.

1. Click the image in the direction you want to correct from the 2 frames of the images except for the image in center.

- The image you clicked is placed in center and 2 new frames of the variation images that have been corrected in each direction are displayed.

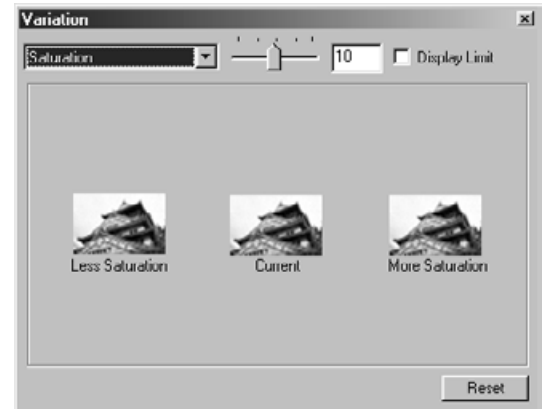

2. Correct the image properly by repeating the operation in step 1.

Changing the Amount of Correction Step

The amount of correction step can be changed by moving the Variation Amount Control slider. The desired amount can also be input in the text box.

Reset

If you click the Reset button, the settings in the current correction window are reset.

SNAPSHOT

When the Snapshot button is clicked, the current prescan image is stored in the Snapshot Display Area temporarily and displayed as a thumbnail.

When the thumbnail in the Snapshot Display Area is double-clicked, that image is displayed in the Prescan tab.

This is convenient when storing the image correction temporarily while processing, or when correcting the image again after going back to a certain step.

Storing in the Snapshot Display Area temporarily

1. Click on .

- The displayed prescan image is displayed in the Snapshot Display Area as a temporary storing place.



Snapshot Display Area 1

Displaying the image stored temporarily as a prescan image

1. Click on the thumbnail in the Snapshot Display Area.

- The displayed prescan image is deleted and the thumbnail image is displayed as a prescan image.



Snapshot Display Area 2

CANCELLING IMAGE CORRECTION

Cancelling the Image Correction

When the Undo button is clicked, the current image correction is cancelled and the image returns to the previous one.

Redo the Correction

When the Redo button is clicked, the cancelled image correction can be resumed.

Delete the Image Correction

When the Correction Reset button in the Image Correction tab is clicked, all the image corrections are deleted and the image returns to the initial state.

Full-Screen View

This function allows you to display a full screen view of the corrected image in the Image Correction tab.

1. Click on .

- When  is clicked, the size of pre and post correction image is automatically changed according to the size of the Main window.

Checking the Correction Result While Lining Up Images

When  is clicked, the Image correction tab is divided into right and left sides, the pre-correction image is displayed on the left side, and post-correction image is displayed on the right side.

JOB SAVE/JOB LOAD

The image correction setting in the correction window can be saved as an image correction job. You can easily correct the image by loading the most appropriate previously saved correction job.

Saving an Image Correction Job

1. Click on  in the Image correction tab.
 - The Register Image Correction Job dialog box is displayed.

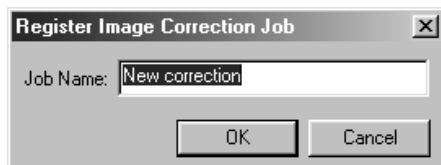

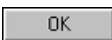
2. Input the job name and click on  .
 - The current image correction setting is saved as an image correction job.

Loading Image Correction Job

This function allows you to load the saved correction job and apply an image correction to the displayed image.

1. Click on  in the Image correction tab.

- The Selected Image Correction Job dialog box is displayed.

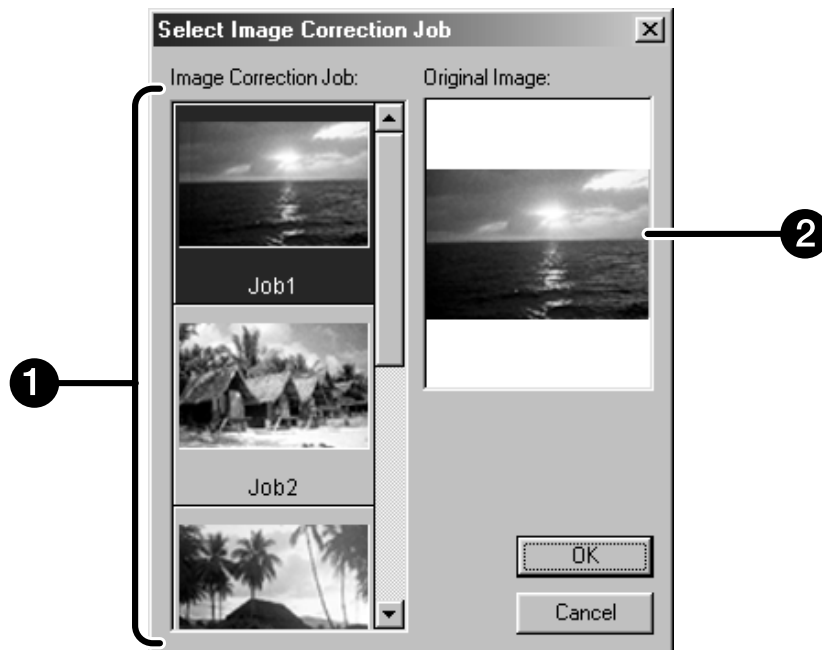

① Image Correction job display area

② Original image display

2. Select the image correction job and click on .

FINAL SCAN

FLOW

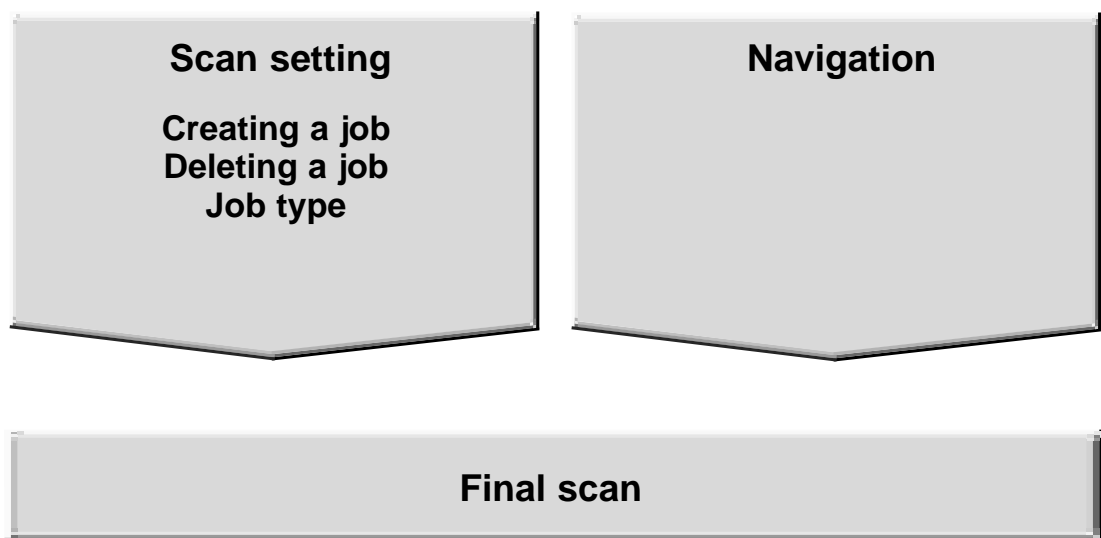

SCAN SETTINGS

The scan settings determine your final image's resolution, dimensions, and file size, as well as helping determine the image quality. You can select a Job (see page 87) to have the scan settings selected for you or you can directly enter them into the Main window (Index tab or Prescan tab).

The Scan Settings part window – Names of parts

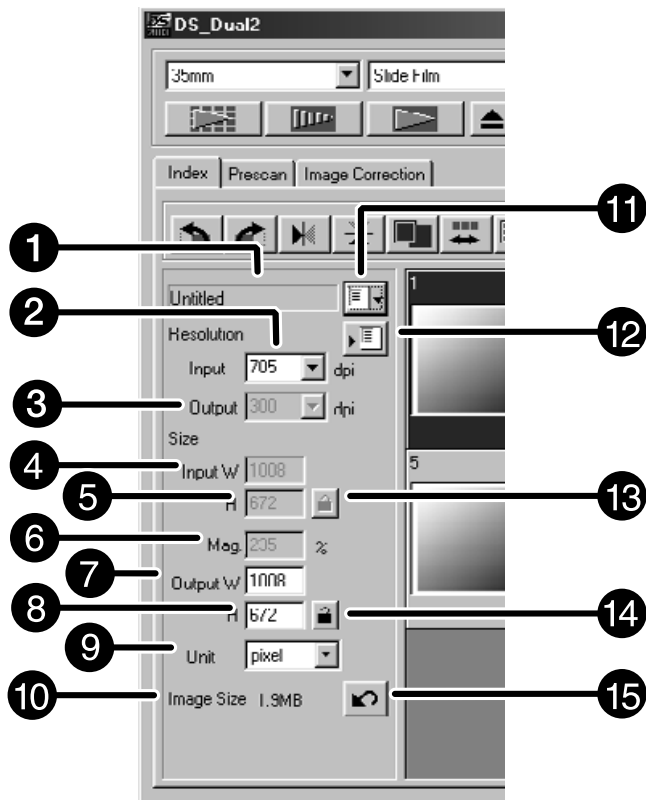

- | | |
|-------------------------------|----------------------------|
| 1 Job Name list box | 8 Output Size text box (H) |
| 2 Input Resolution list box | 9 Unit list box |
| 3 Output Resolution list box | 10 Image Size display |
| 4 Input Size text box (W) | 11 Job Load button |
| 5 Input Size text box (H) | 12 Job Registry button |
| 6 Magnification Size text box | 13 Input size lock button |
| 7 Output Size text box (W) | 14 Output size lock button |
| | 15 Reset button |

Image resolution is the number of pixels per inch (ppi or dpi) that represent your scanned image. The size of an image file is determined by its size (dimensions) and resolution. The rule to follow when scanning is "bigger is better". To obtain the best results, set the output resolution to the highest value your final output device (printer, monitor, etc.) can handle. The driver software automatically determines the input resolution necessary to obtain the desired output size and resolution.

1. Click on .

The Job Selection dialog box will appear.

2. Select the appropriate category from the drop-down list.

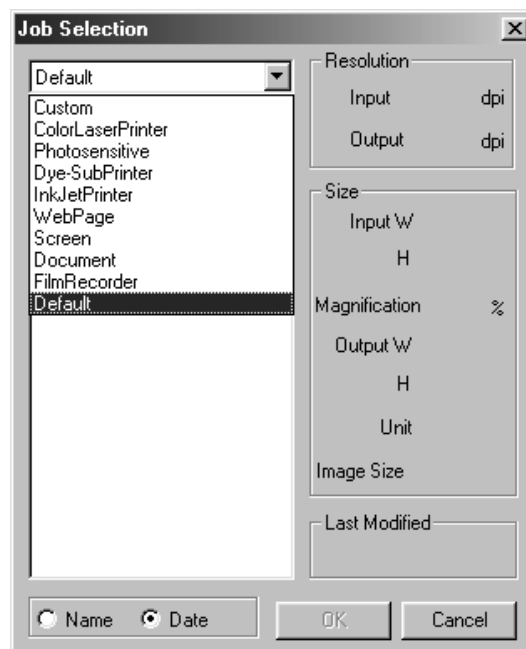

3. Click on the job file name to select it, then click on .

- The settings are applied to the active Prescan window.

NOTE:

Job names can be listed chronologically or alphabetically. Select the format by clicking on the Name or Date option button.

- The cropping frame changes accordingly, but can be proportionally resized.

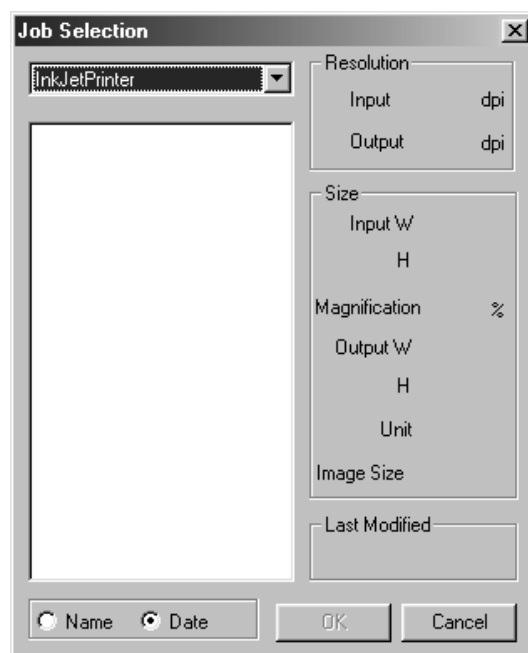

4. Enter the desired output resolution from the output resolution drop-down list.

- Values can also be entered into the output resolution list box directly.

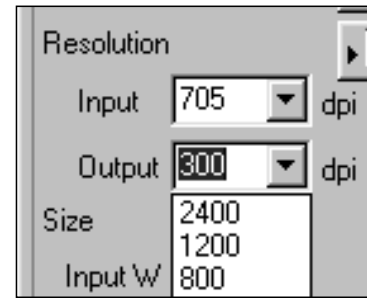

5. The dimensions of the cropping frame are displayed in the input size text boxes.

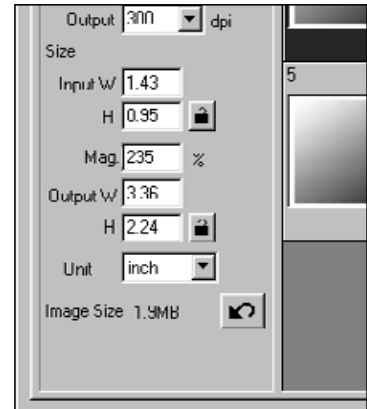

- Values can be entered directly or by resizing the cropping frame.
- The values will change if a different unit of measure is selected.
- The scanning area size can't be changed if the Input Size is locked.



6. Enter the desired output size (maximum 3 digits).

- The output size is limited by the maximum resolution of the scanner.
- The values will change if a different unit of measure is selected.
- The output size cannot be changed when the unit list box is set to pixels.
- The scanning area size can be changed proportionally (within the resolution limits) when the Output Size is locked.

NOTE:

- Click on  to lock the settings. The icon will change to . Click again to unlock.
- The magnification text box displays the output/input size ratio as a percentage.
- Magnification values can be entered directly.

7. The input scan resolution text box is set to the lowest input (scan) resolution necessary to achieve the desired output size and resolution.

- Input scan resolutions can also be selected from the drop down list or entered directly.

CREATING/DELETING JOB FILES

Creating a Job

In addition to the Job settings included with the software, it is possible to create and save your own Job settings.

1. Set the desired settings in the Main window (Index tab or Prescan tab).

2. Click on .

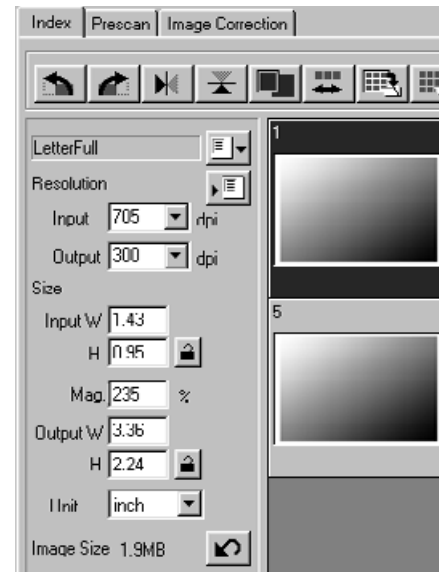

The Job Registry dialog box will appear

3. Name the job by entering a title and select the desired category, then click on .

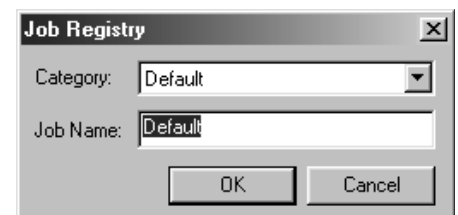

Deleting a Job

It is possible to delete the Job you created when it is no longer needed.

1. Click on the name of the job in the Main window scan settings part, then press the delete key on your keyboard.

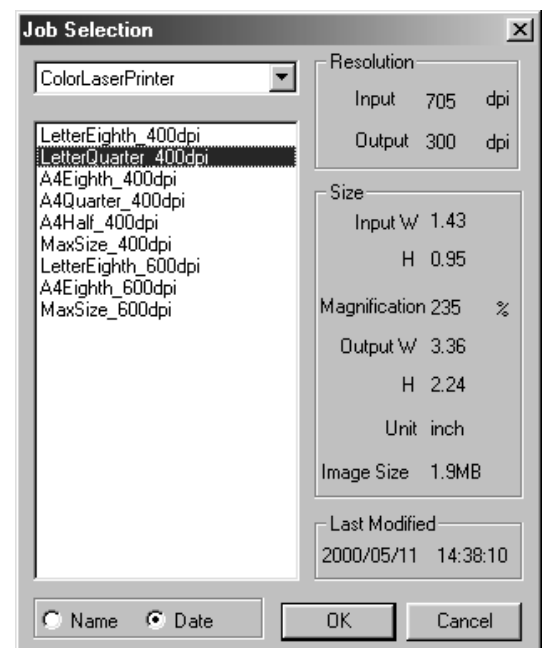

SCAN JOB TYPE

Before making the final scan, the scanner needs to know how big the final image will be and the quality of output that will be used (printer, monitor, etc.) so it knows what resolution to scan the film. Using the Job function is a quick and easy way to enter the scan settings.

Scan Job Category	Description
Custom	User created scan settings (see page 84).
Color Laser Printer	Digital color copiers and color laser printers Uses output resolution of 400 or 600 dpi. There are two paper-size options; letter and A4.
Photosensitive	Printers that use photosensitive/photographic material Can use output resolutions of 400 dpi, 360 dpi, 267 dpi, and 180 dpi. There are ten paper size options.
Dye-Sub Printer	Dye-sublimation printers Uses an output resolution of 300 dpi. There are 4 paper size options.
Ink Jet Printer	Uses an output resolution of 200 dpi. There are 4 paper size options.
Web Page	For use on home pages Image size is listed in pixels and will vary. Standard Photo CD sizes are also available.
Screen	For monitor display Image size is listed in pixels and will be the VGA standard of 640 x 480 pixels or larger.
Document	For insertion into documents Uses an output resolution of 72 dpi. Image size depends on the paper size selected.
Film Recorder	For high input resolution images that will be output to a film recorder.
Default	This category uses the default settings for the film format. The scan settings appear in the Job Selection window.

FINAL SCAN

Scan the film according to the Prescan settings.

With the Dimage Scan Dual2 utility software, you can save the final scan in one of the following file formats.

- JPEG
- BMP (Windows only)
- TIFF
- PICT (Macintosh operating system only)

The image file of 48 bit (16 bit each RGB) can only be saved in the tiff format.

Twain Driver/Plug-in Software

With the Prescan image displayed in the Prescan tab...

1. Click on  in the Main window.
 - The final scan will begin.
 - When scanning is complete, the final scan will appear in the host applications window.
2. Save the image using the instructions for your host application.
3. Close the Control Window to exit the Dimage Scan Dual2 driver software.
 - The driver window will close automatically after each scan if the Close Driver After Scanning option was selected in the Preferences dialog box (see page 39).

Utility Software

With the Prescan image displayed in the Prescan tab...

1. Click on  in the Main window.

Your system's standard save dialog box will appear.

2. Enter the desired file name and select the file destination.
3. Select the file type from the drop-down list.

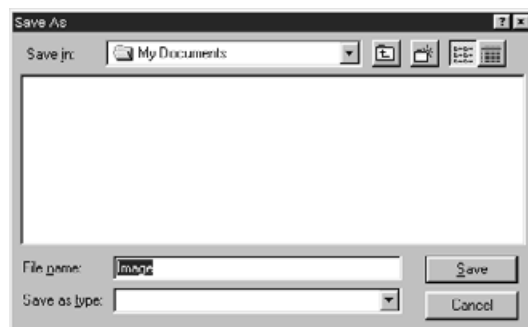

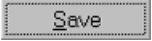
4. Click on .
 - The final scan will begin.
 - When scanning is complete, the scan will be saved in the selected location. The software will return to the Prescan tab.
5. Close the Control Window to exit the Dimage Scan Dual2 driver software.
 - The driver window will close automatically after each scan if the Close Driver After Scanning option was selected in the Preferences dialog box (see page 39).

NAVIGATION

The Navigation window allows you to automate the procedure of scanning. When the Navigation button is clicked in the Main window, the Navigation dialog box is displayed.

The Navigation Dialog box – Name of parts

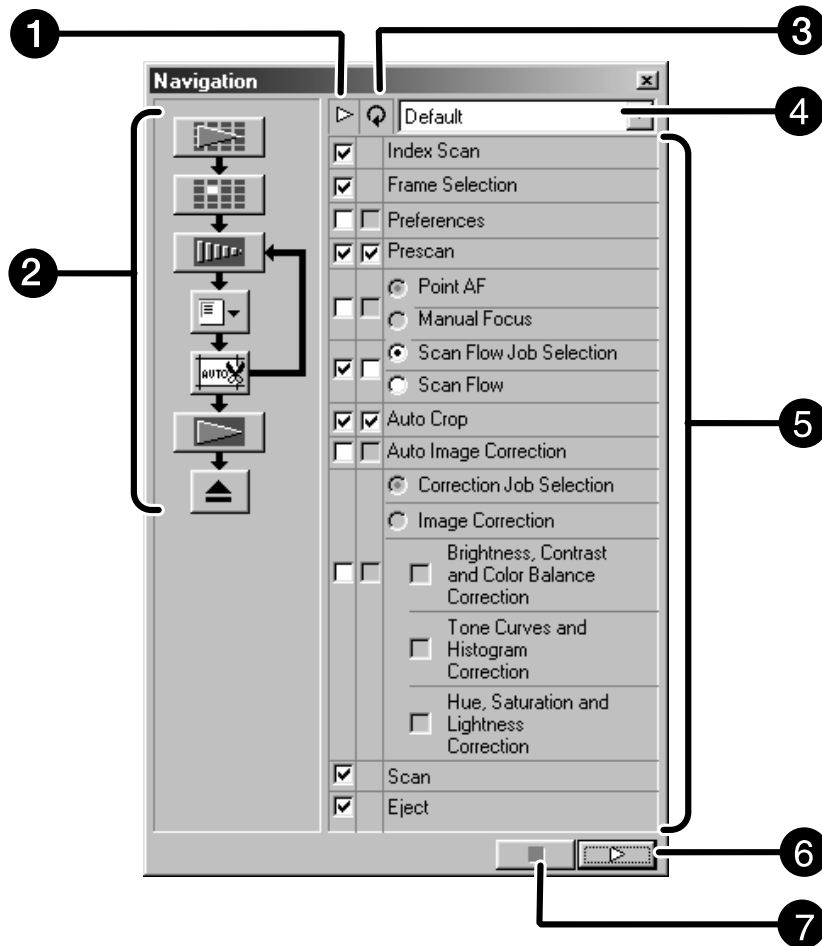

1 Operation Item checkbox

5 Operation Items

2 Navigation Flow

6 Navigation Start button

3 Repeated Operation Item checkbox

7 Navigation Stop button

4 Navigation Menu list box

Navigation Menu

This menu allows you to select the saved setting for automatic operation. Not only the saved settings but the “Save Setting” and “Delete Setting” items are displayed in this menu.

- 1. Select the operation items in the Operation Item Checkbox or Repeated Operation Item checkbox.**
 - The selected items are displayed with the buttons and arrows as a Navigation Flow.
- 2. Click on .**
 - To stop, click the Navigation Stop button.

Operation item checkbox

- 1. Insert the check mark in the operation items to be performed as part of the automatic operation.**

Repeated operation item checkbox

Repeated operation items are only used when scanning a series of selected frames.

- 1. Insert the check mark in the operation items to be performed for all selected frames every time you execute the automatic operation.**

Operation items

The operation items in the automatic operation are displayed.

- 1. Select the details of the operation items with the radio button or checkbox.**

Saving, Selecting and Deleting a Navigation Setting

This function allows you to save the navigation settings. The above settings can be saved, selected or deleted in the Navigation Menu list box.

Saving a Navigation setting

- 1. Click on the arrow next to the Navigation menu list to display the available menu.**
- 2. Select saving setting.**
 - The navigation set saving dialog box is displayed.
- 3. Input the setting name and click the OK button.**

Selecting navigation setting

- 1. Click on the arrow next to the Navigation menu list to display the available menu.**
- 2. Select the setting to be used.**

Deleting navigation setting

- 1. Click on the arrow next to the Navigation menu list to display the available menu.**
- 2. Select the setting to be deleted.**
 - The navigation set deleting dialog box is displayed.
- 3. Select the setting to be deleted and click the Delete button.**

APPENDIX

Color matching

Scan job file list

Glossary

Trouble shooting

Specifications

User technical support

COLOR MATCHING

The function allows you to match the scanner data to the monitor specification (color space). Colors in the original film are reproduced on the monitor with a high fidelity. The output color space and the monitor ICC profile can be specified with the color matching function.

To match the scanner data to the color space, specify the output color space.

To correct the color reproduction character of the monitor and to reduce the difference of color between monitors in different environments in addition to the color space setting, specify the monitor ICC profile settings in both the driver software and a software such as Photoshop. For details, refer to page 95.

1. Click on  in the Main window.

The Color Matching in the Preference Dialog Box – Name of parts

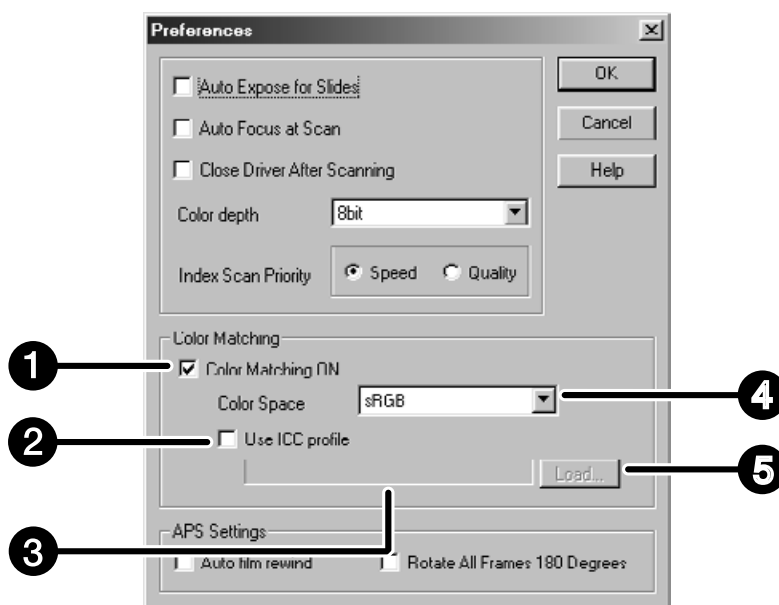

- | | |
|------------------------------|-------------------------------|
| 1 Color Matching ON checkbox | 4 Output Color Space list box |
| 2 Use ICC profile checkbox | 5 ICC profile Load button |
| 3 ICC profile text box | |

2. Set the preferences as desired.

- De-select the Close Driver After Scanning check box when scanning multiple images at the same time.

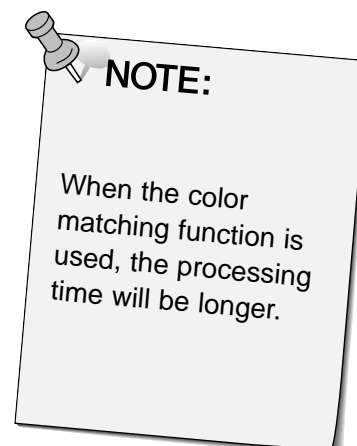

Output color space setting

1. Insert the check mark in the “Color Matching ON” checkbox.
2. Click the ▼ (menu) button in the Output Color Space list box, the available output color space settings are displayed.
3. Click the desired output color space setting.

ICC profile setting

1. Insert the check mark in the “Use ICC profile” checkbox.
2. Click the ICC profile Load button.
 - The standard file open dialog of your operating system is displayed.
3. Select the ICC profile according to the monitor being used.

The application may perform the original matching process. If you want to change the setting, refer to the following sample settings.
And, when the color matching function is used, the color matching function of OS, video card, etc. are set to OFF.

When using an application of which the monitor color matching function is set to ON

Output color space* ¹):	The same color space as specified in the application is specified.
ICC profile* ²):	use

When using an application of which the monitor color matching function is set to OFF, or when using an application which does not have the monitor color matching function.

Output color space:	do not specify
ICC profile* ²):	use

When an image is scanned with this setting, the data is matched to the monitor being used.

*¹) The same color space as specified in the application is specified.

*²) ICC profile specifies the ICC profile of the monitor being used.

SCAN JOB FILE LIST – 35MM

For your reference, the following is a listing of the scan job categories and names for the 35mm and APS film formats.

Category	Job name	Resolution		Mag.	Unit	Input Size		Input Lock	Output Size		Output Lock
		In	Out			W	H		W	H	
Default	Default	705	300	235	pixel	1008	672	OFF	1008	672	OFF
Color Laser Printer	Max Size_600dpi	2820	600	470	mm	36.3	24.2	OFF	170.00	113.00	ON
	A4Quarter_600dpi	2447	600	407	mm	36.3	24.2	OFF	148.00	98.70	ON
	A4Eighth_600dpi	1735	600	289	mm	36.3	24.2	OFF	105.00	70.00	ON
	Letter Quarter_600dpi	2291	600	381	inch	1.43	0.95	OFF	5.46	3.64	ON
	Letter Eighth_600dpi	1702	600	283	inch	1.43	0.95	OFF	4.05	2.70	ON
	Max Size_400dpi	2820	400	705	mm	36.3	24.2	OFF	256.00	170.00	ON
	A4Half_400dpi	2313	400	578	mm	36.3	24.2	OFF	210.00	140.00	ON
	A4Quarter_400dpi	1629	400	407	mm	36.3	24.2	OFF	147.00	98.00	ON
	A4Eighth_400dpi	1156	400	289	mm	36.3	24.2	OFF	105.00	69.90	ON
	Letter Half_400dpi	2291	400	572	inch	1.42	0.95	OFF	8.19	5.46	ON
	Letter Quarter_400dpi	1526	400	381	inch	1.43	0.95	OFF	5.45	3.63	ON
	Letter Eighth_400dpi	1133	400	283	inch	1.43	0.95	OFF	4.05	2.70	ON
Photosensitive	Max Size	2820	400	705	mm	36.3	24.2	OFF	256.00	170.00	ON
	A5_400dpi	2313	400	578	mm	36.3	24.2	OFF	210.00	140.00	ON
	8x10_400dpi	2798	400	699	inch	1.43	0.95	OFF	10.00	6.66	ON
	5x7_400dpi	1961	400	490	inch	1.43	0.95	OFF	7.01	4.67	ON
	PostCard4 6_400dpi	1678	400	419	inch	1.43	0.95	OFF	6.00	4.00	ON
	Letter_267dpi	2039	267	763	inch	1.43	0.95	OFF	10.90	7.27	ON
	A4_267dpi	2187	267	819	mm	36.3	24.2	OFF	297.00	198.00	ON
	A5_267dpi	1545	267	578	mm	36.3	24.2	OFF	210.00	140.00	ON
	8x10_267dpi	1870	267	700	inch	1.43	0.95	OFF	10.00	6.67	ON
	5x7_267dpi	1307	267	489	inch	1.43	0.95	OFF	7.00	4.66	ON
	PostCard4 6_267dpi	1120	267	419	inch	1.43	0.95	OFF	6.00	4.00	ON
	(unavailable)	1597	360	443	mm	36.3	24.2	OFF	161.00	107.00	ON
	2L_360dpi	1727	360	479	mm	36.3	24.2	OFF	174.00	116.00	ON
	14x17_180dpi	2123	180	1179	mm	36.3	24.2	OFF	428.00	285.00	ON
	11x14_180dpi	1747	180	970	mm	36.3	24.2	OFF	352.00	235.00	ON
	10x12_180dpi	1494	180	830	mm	36.3	24.2	OFF	301.00	200.00	ON
	(unavailable)	797	180	442	mm	36.3	24.2	OFF	160.00	106.00	ON
	2L_180dpi	857	180	476	mm	36.3	24.2	OFF	173.00	115.00	ON
Dye-Sub Printer	A4Full	2455	300	818	mm	36.3	24.2	OFF	297.00	198.00	ON
	A4Half	1735	300	578	mm	36.3	24.2	OFF	210.00	140.00	ON
	A4Quarter	1223	300	407	mm	36.3	24.2	OFF	148.00	98.70	ON
	A4Eighth	866	300	289	mm	36.3	24.2	OFF	104.00	69.90	ON
	Letter Full	2291	300	763	inch	1.43	0.95	OFF	10.90	7.28	ON
	Letter Half	1714	300	571	inch	1.43	0.95	OFF	8.17	5.44	ON
	Letter Quarter	1144	300	381	inch	1.43	0.95	OFF	5.45	3.63	ON
	Letter Eighth	850	300	283	inch	1.43	0.95	OFF	4.05	2.70	ON
	(unavailable)	1223	300	407	mm	36.3	24.2	OFF	148.00	98.70	ON
	Photo4x6	1240	300	413	mm	36.3	24.2	OFF	150.00	100.00	ON
	Photo3x5 /Photo9x13	1049	300	349	mm	36.3	24.2	OFF	127.00	84.60	ON
Ink-Jet Printer	A4Full	163	200	818	mm	36.3	24.2	OFF	297.00	198.00	ON
	A4Half	1156	200	578	mm	36.3	24.2	OFF	210.00	139.00	ON
	A4Quarter	814	200	407	mm	36.3	24.2	OFF	148.00	98.50	ON
	A4Eighth	577	200	288	mm	36.4	24.3	OFF	105.00	69.80	ON
	Letter Full	1526	200	763	inch	1.42	0.95	OFF	10.90	7.27	ON
	Letter Half	1144	200	572	inch	1.42	0.95	OFF	8.17	5.45	ON
	Letter Quarter	763	200	381	inch	1.43	0.95	OFF	5.45	3.63	ON
	Letter Eighth	566	200	283	inch	1.43	0.95	OFF	4.05	2.70	ON
	(unavailable)	814	200	407	mm	36.3	24.2	OFF	148.00	98.50	ON
	Photo4x6	826	200	413	mm	36.3	24.2	OFF	150.00	100.00	ON
	Photo3x5 /Photo9x13	699	200	349	mm	36.3	24.0	OFF	127.00	84.50	ON

SCAN JOB FILE LIST – 35MM

Category	Job Name	Resolution		Mag.	Unit	Input Size		Input Lock	Output Size		Output Lock
		In	Out			W	H		W	H	
Web Page	1023 x 682	716	300	238	pixel	1023	682	OFF	1023	682	ON
	960 x 640	671	300	223	pixel	960	640	OFF	960	640	ON
	870 x 580	608	300	202	pixel	870	580	OFF	870	580	ON
	768 x 512	537	300	179	pixel	768	512	OFF	768	512	ON
	624 x 416	436	300	145	pixel	624	416	OFF	624	416	ON
	600 x 400	419	300	139	pixel	600	400	OFF	600	400	ON
	480 x 320	335	300	111	pixel	480	320	OFF	480	320	ON
	Photo CD 2048 x 3072	2148	300	716	pixel	3072	2048	OFF	3072	2048	ON
	Photo CD 1024 x 1536	1074	300	358	pixel	1536	1024	OFF	1536	1024	ON
	Photo CD512 x 768	537	300	179	pixel	768	512	OFF	768	512	ON
Photo CD256 x 348	243	300	81	pixel	348	232	OFF	348	232	ON	
Screen	1280 x 1024	895	300	298	pixel	1280	853	OFF	1280	853	ON
	1280 x 960	895	300	298	pixel	1280	853	OFF	1280	853	ON
	1152 x 870	805	300	268	pixel	1152	768	OFF	1152	768	ON
	1024 x 768	716	300	238	pixel	1024	682	OFF	1024	682	ON
	832 x 624	582	300	194	pixel	832	554	OFF	832	554	ON
	800 x 600	559	300	186	pixel	800	533	OFF	800	533	ON
	640 x 480	47	300	149	pixel	640	426	OFF	640	426	ON
Document	A4 Half	416	72	577	mm	36.3	24.2	OFF	210.00	139.00	ON
	A4 Quarter	293	72	406	mm	36.4	24.1	OFF	148.00	98.40	ON
	A4 Eighth	207	72	287	mm	36.4	24.3	OFF	105.00	70.00	ON
	Letter Half	411	72	570	inch	1.43	0.95	OFF	8.16	5.44	ON
	Letter Quarter	274	72	379	inch	1.43	0.95	OFF	5.44	3.62	ON
	Letter Eighth	203	72	281	inch	1.44	0.96	OFF	4.04	2.69	ON
Film Recorder	35mm Full-Frame	2382	2400	99	mm	36.30	24.20	OFF	36.00	24.00	ON
	35mm Half-Frame	1586	2400	66	mm	36.30	24.20	OFF	24.00	16.00	ON
	35mm Quarter-Frame	1189	2400	49	mm	36.7	24.40	OFF	18.00	11.90	ON

SCAN JOB FILE LIST – APS

Category	Job name	Resolution		Mag.	Unit	Input Size		Input Lock	Output Size		Output Lock
		In	Out			W	H		W	H	
Default	Default	705	300	235	pixel	832	480	OFF	832	480	OFF
Color Laser Printer	Max Size_600dpi	2820	600	470	mm	29.9	17.2	OFF	140.00	81.20	ON
	A4 Eighth_600dpi	2104	600	350	mm	30.0	17.3	OFF	105.00	60.60	ON
	Letter Eighth_600dpi	2161	600	360	inch	1.18	0.68	OFF	4.25	2.45	ON
	Max Size_400dpi	2820	400	705	mm	29.9	17.2	OFF	211.00	121.00	ON
	A4 Half_400dpi	2809	400	702	mm	29.9	17.2	OFF	210.00	121.00	ON
	A4 Quarter_400dpi	1977	400	494	mm	30.0	17.3	OFF	148.00	85.40	ON
	A4 Eighth_400dpi	1401	400	350	mm	30.0	17.3	OFF	105.00	60.60	ON
	Letter Quarter_400dpi	1851	400	462	inch	1.18	0.68	OFF	5.46	3.15	ON
Letter Eighth_400dpi	1440	400	360	inch	1.18	0.68	OFF	4.25	2.45	ON	
Photosensitive	Max Size	2820	400	705	mm	29.9	17.2	OFF	211.00	121.00	ON
	A5_400dpi	2809	400	702	mm	29.9	17.2	OFF	210.00	121.00	ON
	5x7_400dpi	2374	400	593	inch	1.18	0.68	OFF	7.00	4.04	ON
	Post Card 4 x 6_400dpi	2039	400	509	inch	1.18	0.68	OFF	6.01	3.47	ON
	Letter_267dpi	2472	267	925	inch	1.18	0.68	OFF	10.90	6.30	ON
	A4_267dpi	2654	267	994	mm	29.9	17.2	OFF	297.00	171.00	ON
	A5_267dpi	1870	267	700	mm	30.0	17.2	OFF	210.00	121.00	ON
	8x10_267dpi	2263	267	847	inch	1.18	0.68	OFF	10.00	5.76	ON
	5x7_267dpi	1586	267	594	inch	1.17	0.68	OFF	7.00	4.04	ON
	PostCard4 x 6_267dpi	1359	267	508	inch	1.18	0.68	OFF	6.00	3.46	ON
	(unavailable)	1935	360	537	mm	30.0	17.3	OFF	161.00	92.90	ON
	2L_360dpi	2092	360	581	mm	29.9	17.2	OFF	174.00	100.00	ON
	14x17_180dpi	2578	180	1432	mm	29.9	17.2	OFF	429.00	247.00	ON
	11x14_180dpi	2117	180	1176	mm	29.9	17.2	OFF	352.00	203.00	ON
10x12_180dpi	1809	180	1005	mm	29.9	17.2	OFF	301.00	173.00	ON	
(unavailable)	966	180	536	mm	30.0	17.2	OFF	160.00	92.70	ON	
2L_180dpi	1046	180	581	mm	29.9	17.2	OFF	174.00	100.00	ON	
Dye-Sub Printer	Max Size	2820	300	940	mm	29.9	17.2	OFF	281.00	162.00	ON
	A4 Half	2104	300	701	mm	29.9	17.3	OFF	210.00	121.00	ON
	A4 Quarter	1482	300	494	mm	29.9	17.2	OFF	148.00	85.40	ON
	A4 Eighth	1050	300	350	mm	30.0	17.3	OFF	105.00	60.50	ON
	Letter Full	2776	300	925	inch	1.18	0.68	OFF	10.90	6.30	ON
	Letter Half	2161	300	720	inch	1.18	0.68	OFF	8.50	4.90	ON
	Letter Quarter	1385	300	461	inch	1.18	0.68	OFF	5.45	3.14	ON
	Letter Eighth	1080	300	360	inch	1.18	0.68	OFF	4.25	2.45	ON
	(unavailable)	1500	300	500	mm	30.0	17.2	OFF	150.00	86.40	ON
	Photo 9x13	1270	300	423	mm	30.0	17.2	OFF	127.00	73.00	ON
	(unavailable)	1977	200	988	mm	30.0	17.3	OFF	297.00	171.00	ON
Ink-Jet Printer	A4 Full	1977	200	988	mm	30.0	17.3	OFF	297.00	171.00	ON
	A4 Half	1401	200	700	mm	30.0	17.3	OFF	210.00	121.00	ON
	A4 Quarter	987	200	493	mm	30.0	17.3	OFF	148.00	85.30	ON
	A4 Eighth	700	200	350	mm	30.0	17.3	OFF	105.00	60.40	ON
	Letter Full	1846	200	923	inch	1.18	0.68	OFF	10.90	6.28	ON
	Letter Half	1440	200	720	inch	1.18	0.68	OFF	8.50	4.90	ON
	Letter Quarter	924	200	462	inch	1.17	0.68	OFF	5.45	3.14	ON
	Letter Eighth	720	200	360	inch	1.18	0.68	OFF	4.25	2.45	ON
	Photo 4 x 6	1001	200	500	mm	30.0	17.3	OFF	150.00	86.40	ON
Photo 3.5 x 5/Photo 9 x 13	846	200	423	mm	30.0	17.2	OFF	127.00	73.00	ON	
Web Page	1280 x 739	1085	300	361	pixel	1280	739	OFF	1280	739	ON
	1152 x 665	976	300	665	pixel	1152	665	OFF	1152	665	ON
	1024 x 590	867	300	239	pixel	1024	590	OFF	1024	590	ON
	832 x 480	705	300	235	pixel	832	480	OFF	832	480	ON
	800 x 461	678	300	226	pixel	800	461	OFF	800	461	ON
	640 x 369	542	300	180	pixel	640	369	OFF	640	369	ON
	Photo CD1024 x 1536	1303	300	434	pixel	1536	887	OFF	1536	887	ON
	Photo CD512 x 768	650	300	216	pixel	768	443	OFF	768	443	ON
Photo CD256 x 348	294	300	98	pixel	348	200	OFF	348	200	ON	
Screen	1280 x 1024	1085	300	361	pixel	1280	739	OFF	1280	739	ON
	1280 x 960	1085	300	361	pixel	1280	739	OFF	1280	739	ON
	1152 x 870	976	300	325	pixel	1152	665	OFF	1152	665	ON
	1024 x 768	867	300	289	pixel	1024	590	OFF	1024	590	ON
	832 x 624	705	300	235	pixel	832	480	OFF	832	480	ON
	800 x 600	678	300	226	pixel	800	461	OFF	800	461	ON
	640 x 480	542	300	369	pixel	640	369	OFF	640	369	ON
Document	A4 Half	504	72	700	mm	30.0	17.3	OFF	210.00	121.00	ON
	A4 Quarter	355	72	493	mm	30.0	17.3	OFF	148.00	85.00	ON
	A4 Eighth	251	72	348	mm	30.0	17.3	OFF	105.00	60.30	ON
	Letter Half	518	72	719	inch	1.18	0.68	OFF	8.50	4.90	ON

GLOSSARY

BRIGHTNESS	The lightness or darkness of the image.
CHANNEL	The component of an image. Your scanned image has three channels: red, green, and blue (RGB).
CONTRAST	The gradation of shades in an image. A high contrast image has very dark areas and bright areas without many middle shades. A low contrast image has many tones that are close to the same brightness. Low contrast images are often described as looking 'flat'.
CROP	To trim and delete the unwanted edges of the image.
DPI	Dots (pixels) per inch.
EMULSION SIDE	The side of the film coated with the photographic material.
GAMMA	The contrast of only the middle tones.
HIGHLIGHTS	The lighter areas of the image.
HISTOGRAM	A graph showing the amount of each level of the 256 brightness levels.
INTERPOLATION	A form of adding new pixels in an image when resampling up.
JPEG	The JPEG (Joint Photographic Experts Group) compression standard is capable of producing a high compression ratio while maintaining image quality. JPEG is a widely supported image file format.
MIDTONE	The middle shades of an image, in between light and dark.
NEUTRAL	Having no color cast, such as black, white, or gray.
PICT	(Macintosh operating system only) The PICT graphic file format uses a lossless compression scheme and is compatible with many Macintosh applications.
PIXEL	Abbreviation for picture element. The dots that make up an electronic image.

RESAMPLE	To change the number of pixels in the image. If pixels are discarded when shrinking an image, it is called resampling down. If new pixels are created in an image, it is called resampling up (see page 100).
RESOLUTION	The number of pixels in a given area of the image; such as pixels per inch or pixels per centimeter. High resolution is the term for an image with a lot of pixels in a given area. Low resolution means there are not many pixels in a given area.
RGB	Red, Green, and Blue. These are the colors of the three channels that make up the scanned image. Monitors use red, green, and blue phosphors to create the image you see on the screen.
SHADOWS	The dark areas of an image.
TIFF	Tagged Image File Format (TIFF) files contain bit-mapped data. In addition to being a widely supported format, TIFF is able to handle the color palette needed for professional-quality images and graphics.
USB	<p>In the USB connection, the peripheral devices such as a mouse, printer, scanner, etc. can be connected up to 127 with an interface. Furthermore, the peripheral equipment can be easily set up because the USB connection does not require to specify the ID number or the terminator for each equipment compared with the SCSI devices.</p> <p>It does not matter whether the USB equipment or computer is turned on or off first.</p> <p>In the USB connection, the USB equipment or computer can be connected or disconnected even while the equipment is turned on.</p> <p>When disconnecting and connecting the USB equipment, perform at an interval of 5 seconds or more.</p>
WINDOWS® BMP	(Windows only) The BMP graphic file format is for bit-mapped images. BMP images are supported by the Paint accessory and can easily be opened on most PCs running Windows.

TROUBLE SHOOTING

SYMPTOM or MESSAGE

SOLUTION

The computer will not start up after connecting the scanner.

- Shut down the computer and all the devices in your USB chain, then check the USB cables and AC power adapter cord.

DS_Dual2 does not appear in the Import drop down list.

- Make sure the plug-in module has been placed in the correct folder. See page 21.

“Could not establish connection with scanner.”

- Indicator lamp is off – Turn the Dimâge Scan Dual2 on, then restart your system.

“Setting up now. Remove the film holder.”

- Remove the film holder and click on OK.

Indicator lamp blinking rapidly (8Hz).

- Scanner door opened during setup. Close scanner door.

“Set film properly...”

- Load film into the film holder.

“Set 35mm film holder properly.”

- Set the correct film type.

“Set APS film holder properly.”

- Set the correct film type.

“Could not recognise the film type.”

- Set the film type manually.

“Insufficient Memory”

- Increase the memory requirements for the host application.
- If you have scanned multiple images, close and relaunch the host application.

“Setting up now. Remove the film holder.” appears when the film holder is not loaded.

- Contact a Minolta Service Facility to change the fluorescent lamp.

SPECIFICATIONS

Type:	Fixed sensor, film transport, single pass
Usable Film:	35mm – negative/positive, color/B&W APS cassette (with optional adapter) – color/B&W, negative/positive
Scanning Dimensions:	35mm – 24.2 x 36.3mm (2688 x 4032 pixels) APS – 17.28 x 29.95mm (1920 x 3328 pixels)
Optical Input Resolution:	2820 dpi
A/D Conversion:	12 bit
Image Sensor:	RGB 3-line CCD (2700 pixels)
Scan Times (approx):	

	35mm	APS
Prescan	10 sec.	11 sec.
Scan	60 sec.	5 sec.
Index Scan	10 sec/frame	10 sec/frame

Testing Conditions

IBM PC/AT
CPU: Pentium III 600MHz; RAM: 256MB;
OS: Windows 98 2nd edition; Software: Twain_32 Source;
Host Application: Adobe Photoshop 5.5; ASPI version: 4.57

Interface:

USB

Light Source:

3 Wavelength Cold Cathode Fluorescent

Power/Frequency:

Using the AC power adapter:

Product for North America: 100-120 volts AC, 50/60 Hz

Product for Europe: 220-240 volts AC, 50/60 Hz

Use only within the voltage range specified on the AC power Adapter.

Power Consumption:

Max. 30W

Dimensions (W x H x D):

150 x 100 x 320mm

Weight (approx):

1.5kg

Specifications are based on the latest information available at the time of printing and are subject to change without notice.

USER TECHNICAL SUPPORT

Please contact your dealer for information regarding installation, USB interface recommendations, or application compatibility. If your dealer is unable to help you, contact an authorized Minolta service center.

Please have the following information ready when calling Minolta Technical Support.

Make and Model of your computer:

Available application RAM:

Operating System version:

Other connected USB devices:

DS Dual2 driver version number:

Symptoms:

Messages that appear on the screen when the problem occurs:

Frequency of occurrence:

Determining the version number of your driver software:

Place the pointer on the status window in the command window to display the version number.

When the “Add New Hardware Wizard” window is displayed

The “Add New Hardware Wizard” window may be displayed in the following cases:

- If you connected the Dimâge Scan Dual II to the PC before installing the Dimâge Scan Dual II driver software.
- If you connected the Dimâge Scan Dual II to the PC after installing the Dimâge Scan Dual II driver software. (for some PCs)
- If you performed from step 1 to 10 described on “When the Dimâge Scan Dual II driver software does not start up”.

When the PC does not recognize the Dimâge Scan Dual II

When the “Add New Hardware Wizard” window is displayed, perform the following operation so that the PC recognizes the Dimâge Scan Dual II.



1. **When the “Add New Hardware Wizard” window is displayed, click on [Next>].**

The window for selecting the way to search for new drivers is displayed.



2. **Make sure that the check mark is put on “Search for the best driver for your device. (Recommended)” and then click on [Next>].**

The window for specifying the location to search is displayed.



3. **Insert the Dimâge Scan Dual II CD-ROM into the CD-ROM drive, put the check mark on “Specify a location” and then enter “E:\inf”. (When the CD-ROM drive is the E drive.)**

Note

The name of the CD-ROM drive differs depending on the setting in the preferences.

4. **Click on [Next>].**

5. Click on [Next>].



6. Click on [Finish].



When the Dimâge Scan Dual II driver software does not start up

In the following cases, “Dimâge Scan Dual II is not connected.” appears and the Dimâge Scan Dual II driver software may not be able to start up even if you attempt to make the Dimâge Scan Dual II start up.

The power of the Dimâge Scan Dual II is not turned on

Make sure that the power of the Dimâge Scan Dual II is turned on and the power cord and the AC power adapter is connected correctly.

The Dimâge Scan Dual II is not connected to the PC correctly

Make sure that the Dimâge Scan Dual II is connected to the PC correctly.

“Dimâge Scan Dual II” does not appear in the Device Manager

When the Dimâge Scan Dual II is displayed as “Unknown Device” or “USB Device”, perform the following procedure so that the PC recognizes the Dimâge Scan Dual II again.

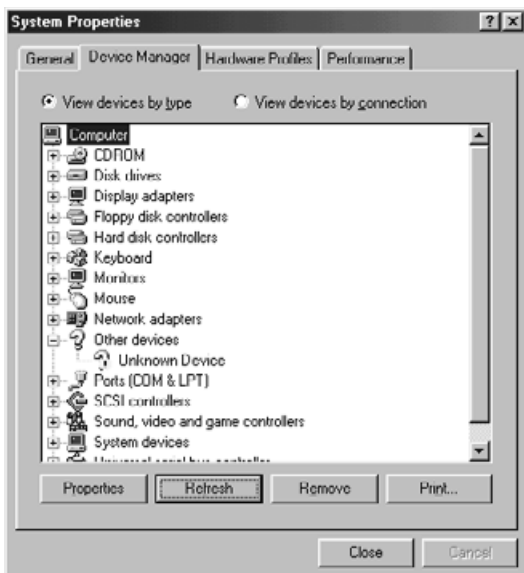

1. Connect the Dimâge Scan Dual II to the PC and turn on the power of the Dimâge Scan Dual II and the PC.

2. Click on “My Computer” on the desk top using the right button of the mouse and then click on “Properties”.

3. Click on the tab of “Device Manager”.

4. Make sure that “USB Device” or “Unknown Device” appears in “Other devices” as displayed left.

5. Click on “USB Device” or “Unknown Device”.

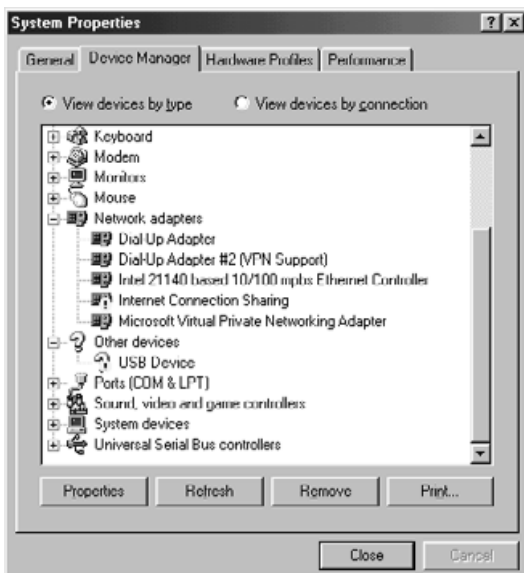

6. Click on [Remove].

The “Confirm Device Removal” window is displayed.

7. Click on [OK].



8. Make sure that neither “USB Device” nor “Unknown Device” appears as displayed left and then click on [Close].

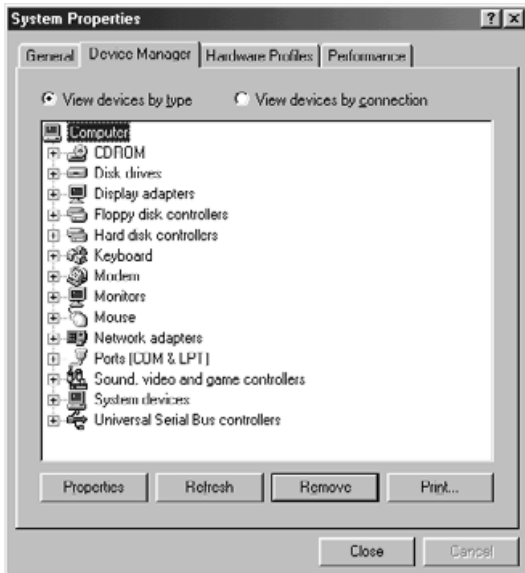

9. Press the power button of the Dimâge Scan Dual II to turn off.

10. Press the power button of the Dimâge Scan Dual II again to turn on.
The “Add New Hardware Wizard” window is displayed.



11. Make the PC recognize the Dimâge Scan Dual II by following the procedure described on “When the “Add New Hardware Wizard” window is displayed”.



FOR WINDOWS 2000 USERS

When using the TWAIN_32 driver with Adobe Photoshop LE (supplied with this scanner), scanning may stop halfway through the scan depending on the memory allocations to Photoshop. In this case, change the memory allocations after closing the driver software by following the procedure described below:

Switch off the scanner.

The driver software can now be closed

Close the driver software.

Select [Memory & Image Cache...] from [Preferences] in [File] menu of Photoshop

The Preferences window will appear.

Change the value* in the box of “Used by Photoshop:” in “Physical Memory Usage” and click on [OK].

*Specify the value from about 20 to 50 (%)

Close Photoshop and then restart it.

Turn on the power of the scanner again, remove the film holder and close the scanner front for set-up.

Restart the Twain_32 driver from Adobe Photoshop LE.

Perform the scanning operation again.

The memory allocations differ according to your system. If the scanning operation still cannot be performed properly even after changing the setting, change the value of the memory allocations again by following the procedure described above.

For the operations of Adobe Photoshop LE (supplied with this scanner) and Adobe Photoshop, please refer to the web site, etc. of Adobe Systems Incorporated.

MINOLTA

- A** Minolta Austria Ges.m.b.H
Amalienstr. 59-61, A-1131 Wien, Österreich
Tel: 01 87868 176
Fax: 01 87868 153
<http://www.minoltaeurope.com>
- B** Minolta Belgium Branch
Prins Boudewijnlaan 1
B-2550 Kontich, België
Tel: 03 451 07 00
Fax: 03 458 50 48
<http://www.minolta.be> en <http://www.minolta.nl>
- CAN** Minolta Canada Inc., Head Office
369 Britannia Road East,
Mississauga, Ontario L4Z 2H5, Canada
Tel. 0905 890 66 00
Fax 0905 890 71 99
<http://www.minolta.com>
- CH** Minolta (Schweiz) AG
Riedstr. 6, CH-8953 Dietikon, Schweiz
Tel: 157 57 11 (sFr 2.15/min)
Fax: 01 741 33 12
<http://www.minolta.ch>
- D** Minolta Europe GmbH
Minoltaring 11,
D-30855 Langenhagen,
Deutschland
- Reparatur/Repair
Senator-Helmken-Strasse 1,
D-28279 Bremen,
Deutschland
- Hotline: Tel: 0221 5 60 60 31
Fax: 0221 5 60 60 40
- <http://www.minolta.de>
- DK** Paul Westheimer A/S
Erhvervsvej 30, DK-2610 Rødovre, Danmark
Tel: 44 85 34 00
Fax: 44 85 34 01
<http://www.minoltaeurope.com>
- E** Videosonic S.A.
c/ Valportillo II, 8, Pol. Ind. de Alcobendas,
E-28108 Alcobendas/Madrid, Spain
Tel: 91 4840077
Fax: 91 4840079
<http://www.minoltaeurope.com>
- F** Minolta France S. A.
365, Route de Saint-Germain,
F-78420 Carrières-Sur-Seine, France
Tel: 0130 86 62 37
Fax: 0130 86 62 82
<http://www.minolta.fr>
- FIN** Minolta Finland Branch
Niittykatu 6, PL 37 SF-02201 Espoo, Finland
Tel: 435 565 0
Fax: 435 565 56
<http://www.minolta.fi>
- GB** Minolta (UK) LTD. Photographic Division
Precedent Drive,
Rooksley, Milton Keynes, MK13 8HF, England
Tel: 01 908 208 349
Fax: 01 908 208 334
<http://www.minoltaeurope.com>
- IRL** Photopak Sales
241 Western Industrial Estate, Naas Road, Dublin 12,
Ireland
Tel: 01 45 66 400
Fax: 01 45 00 452
<http://www.minoltaeurope.com>
- I** Rossi & C. S.p.A.
Via Ticino 40,
I - 50019 Osmannoro Sesto Fiorentino (Fi), Italy
Tel.: 055 323141
Fax: 055 32314252
<http://www.minoltafoto.it>
- N** Scandiafilm AS
Enebakkveien 304, N-1188 Oslo 11, Norge
Tel: 022 28 00 00
Fax: 022 28 17 42
<http://www.minoltaeurope.com>
- NL** Minolta Camera Benelux B.V.
Zonnebaan 39, Postbus 6000
3600 HA Maarssen, Nederland
Tel: 030 247 08 09
Fax: 030 247 08 88
<http://www.minolta.nl>
- P** Minolta Portugal Lda
Av. do Brasil 33-a, P-1700 Lisboa, Portugal
Tel: 01793 00 16
Fax: 01 793 10 64
<http://www.minoltaeurope.com>
- S** Minolta Svenska AB
P. O. Box 9058, Albygatan 114, S-17109 Solna, Sverige
Tel: 08 627 76 50
Fax: 08 627 76 21
<http://www.minoltaeurope.com>
- Sin** Minolta Singapore (Pte) Limited
10 Teban Gardens Crescent, Singapore 2260
Tel: 56 35 533
Fax: 56 10 217
<http://www.minolta.com>